

CV SMART CHOICE FROM

PICKSONS

TRUCK TRAILER & BUS PARTS

ISSUE 24 + APRIL - JUNE 2021 + All offers end 30 June 2021 and are subject to availability. All prices exclude VAT.

OUT NOW! Ask for our comprehensive parts catalogue today...

WE'VE GOT IT COVERED!

TOP PARTS FOR TOP APPLICATIONS INSIDE...



THIS ISSUE...



FOCUS ON SCANIA

PRODUCT FOCUS ON SCANIA TRUCK PARTS
THROUGHOUT THIS ISSUE, see inside for details...

PLUS...



COMMERCIAL LUBRICANTS GUIDE

PULL OUT AND KEEP POSTER
PAGES 12-13



NEW EBS7 COMPONENTS

FOR SCANIA
PAGE 5

WELCOME TO CV SMART CHOICE

ISSUE 24 APRIL – JUNE 2021

Focus on SCANIA

Knorr-Bremse page 5

Dinex page 7

Prestolite page 9

Textar page 10

ZF page 14

Sachs page 15

Automint page 16

Winnard page 16

Donaldson page 18

Dayco page 20

Valeo page 22



INSIDE THIS ISSUE

- 2 febi
- 3 Tecalemit
- 4 Draper / Osram
- 5 Knorr-Bremse / Gates
- 6 Yuasa / Lucas
- 7 Dinex
- 8 Brigade / FAG
- 9 Prestolite
- 10 Textar
- 11 Tubegear
- 12-13 AD Lubricants
- 14 ZF
- 15 Sachs
- 16 Automint / Winnard
- 17 Mahle
- 18 LED Autolamps / Donaldson
- 19 IMS
- 20 Dayco
- 21 Durite / Premier Pits
- 22 Valeo
- 23 Technical Hotlines

CV SMART CHOICE Terms & Conditions

Offers end 30 June 2021. All offers subject to availability and change without notice. Certain featured products may not be stocked by all members. Call your local IFA Member with any stock or pricing queries. These offers cannot be used in conjunction with any offer except at the discretion of your local IFA Member. All prices shown are exclusive of VAT. Pictures used are for illustrative purposes only and products are not shown at actual size or to scale. All product/marketing claims are the responsibility of the company on behalf of whom they are made and are not the liability of the IFA or its agents. E & OE.

All lease payment examples are based on a 60 month repayment period and with a NIL DEPOSIT facility. All lease figures quoted are subject to VAT and status. Alternative lease plans are available and can be tailored to your exact requirements. If you have any questions regarding lease facilities please call Alliance & General Leasing on 02476 22 00 00.

febiTruck

Smart Choices

For Scania Trucks

febi Truck provide a wide range of over 1,300 OE-matching quality parts for Scania Trucks. The S-Series is the largest Truck in Scania's range. Designed for long distance driving comfort it has one of the most luxurious interiors available.



106117
Cabin Tilt Cylinder
P, G, R, S Series (2016-)



£400.00

£49.49



24874
Door Handle (Right)
P, G, R Series (2004-)

£94.91



105838
Bonnet Catch
P, G, R Series (2004-)

24768
Washer Pump for windscreen
P, G, R, S Series (2016-)



£24.00

LCV FOCUS: VW Transporter



Part Number	Description	To Fit
31789	Tie Rod with tie rod end and lock nut	VW Transporter (7E, 7F, 7H, 7J)
171222	Roller Rails for sliding door	VW Transporter (7E)
171772	Transmission Oil and Filter Service Kit	VW Transporter (7E, 7F)
12793	Washer Pumps for windscreen and headlights	VW Transporter (7E, 7F, 7H, 7J)
27834	Stabiliser Link with lock nuts	VW Transporter (7E, 7F, 7H, 7J)
106307	Strut Mounting Kit with ball bearing	VW Transporter (7E, 7F)
45116	Timing Belt Kit with water pump	VW Transporter (7E, 7F)
38285	Control Arm with bush and joint	VW Transporter (7E, 7F, 7H, 7J)

For more information on febi parts contact your local IFA member today!

SOLUTIONS MADE IN GERMANY
www.febi.com

bilsteingroup®



Keeping Big Wheels Turning



Tecalemit Sicam Jumbo Series Tyre Changers

The Sicam range of Commercial Vehicle tyre changers are designed to safely and efficiently handle the size and weight of wheels and tyres in a workshop environment.



From **£6,669**
£35.40p/w

Model (Jumbo Series)	Wheel Size (Diameter, Width, Weight)	Chuck System	Control	Application
TCS/26	26" (d)	Hydraulic 4 Jaw Bi-directional single speed	Wired Remote	CV
TCS/52/NW	810mm (w)*	Hydraulic 4 Jaw Bi-directional twin speed	Wired Remote	CV & Light Agricultural
TCS/52/ANW/MAXI	1230mm (w)*	Hydraulic 4 Jaw Bi-directional twin speed	Wired Remote	CV & Light Agricultural
TCS/56	1190 mm (w)*	Hydraulic 6 Jaw Bi-directional twin speed	Wired Remote	CV & Light Agricultural
TCS/56/R	1190 mm (w)*	Hydraulic 6 Jaw Bi-directional twin speed	Wireless Remote	CV & Light Agricultural
TCS/60	2.9m (d) 1460 mm (w) 2.8 t (wgt)*	Hydraulic 6 Jaw Bi-directional twin speed	Wired Remote	CV & Light Agricultural
TCS/60/R	2.9m (d) 1460 mm (w) 2.8 t (wgt)*	Hydraulic 6 Jaw Bi-directional twin speed	Wireless Remote	CV, Light & Heavy Agricultural plus OTR

* Clamping Capacity 40" (60" With Optional Extensions)

Tecalemit Sicam Tyre Inflation cage

SICAM

- Provides an effective solution for tyre inflation safety
- Accommodates most types of CV wheels
- Car and LCV compatible
- Perforated mesh enclosing structure minimises shock wave
- Weight 166 kg
- External (W,H,D) 1600x1580x800 mm
- Internal (W,H,D) 1500x1500x700 mm
- Pneumatic circuit pressure 10 bar

Part no. 1694/302032

Optional blast inflating system Part no. 1695/700051

Optional Electronic Inflating System, for additional operator protection Part no. 1695/700052

From **£1,999**
£10.61p/w

CV Tyre Changer Accessories

- Tubeless Roller**
Part no. 1695/300102
- OTR – Split ring wheels clamp**
Part no. 1695/300098
- Pneumatic bead depressor**
Part no. 1695/103526
- Extension 56" kit (4 pcs.)**
Part no. 1695/301710
- Light alloy wheel protection for 26" (4 pcs.)**
Part no. 1695/400139

Ask for details on our full range of CV tyre changing accessories

Model	Display	Rim & Wheel Size	Balancing Modes & Capacity	Dimensions	Supply
SBM/V955	Colour LCD screen	20" Rim W 10" to 26.5" Rim D 650mm Wheel W 1200mm Wheel D	Balancing speed 100 rpm (truck mode) 167 rpm (car mode, 50 Hz) 200 rpm (car mode, 60 Hz) 160Kg Capacity	Max. H 1,950mm Max. D 1,350mm W 2,000mm	Power supply 230V, 50-60 Hz Compressed air supply 8-12 bar
SBM/855	Digital				

Tecalemit Sicam Jumbo Series Wheel Balancers

The Sicam range of Commercial Vehicle wheel balancers are designed to safely and efficiently handle the size and weight of wheels and tyres in a workshop environment.

From **£5,439**
£28.87p/w

HAWEKA

From **£5,499**
£29.19p/w

HAWEKA AXIS500 Series Laser Wheel Alignment System

Model	Measurement Capability
HAW/922000050S	Total toe, single toe and rear axle out of square
HAW/922000050	Total toe, single toe and rear axle out of square, camber, caster, KPI and toe-out on turns. Inclinator for measuring turning angles at +/-20° without floor-scales
Optional Accessories	
HAW/922000001	Upgrade kit for trailer and semi-trailer alignment
HAW/923000002	Additional pair of turn plates to enable alignment of vehicles with twin steering axles
HAW/913009048	Optional 3D inclinometer with automatic angle identification
HAW/922000003	Upgrade kit to enable alignment of cars and vans
HAW/922001004	Frame scale with flags for buses and coaches
HAW/922000013	SAD500 Calibration rig for Adaptive Cruise Control radars
HAW/922001020	Reflector for calibration of Lane guard cameras (Use with SAD500 Calibration rig)

Enabling workshops to handle HGV wheels and tyres efficiently and safely

All offers subject to status. For leasing options and terms and conditions please see page 2.



**Pneumatic Jack
(40 Tonne)
02079**

ONLY £699.00

GREAT DEALS ON THESE WORKSHOP ESSENTIALS!





**Needle Scaler
84131**

ONLY £33.00



**Air Impact Wrench (1" Sq. Dr.)
84128**

ONLY £199.95

Due to current pandemic situation, prices and availability may be subject to change. To pre-order now call us for more details.



**1" Sq. Dr. Combined MM/AF
Deep Impact
Socket Set
in Metal Case
(10 Piece)
83283**

ONLY £105.95



**Torque
Multiplier Kit
(5 Piece)
83635**

ONLY £121.25



**Petrol Pressure Washer
(13HP)
83819**

ONLY £599.16

TO FIND OUT MORE CONTACT YOUR LOCAL BRANCH TODAY!

www.osram.co.uk/ledriving-lights





**LEDDL108-WD
£35.71**



**LEDDL109-WD
£35.71**



**LEDDL115-SP
£70.71**



**LEDWL103-WD
£49.29**



**LEDDL116-SP
£92.14**



**LEDDL117-CB
£63.57**



**LEDDL118-CB
£85.00**



**LEDDL119-WD
£42.14**



**LEDDL101-SP
£63.57**



**LEDWL102-SP
£49.29**

Bringing light to life

OSRAM LEDDriving® Driving and Working Lights

OSRAM's LEDDriving® driving* and working** lights offer powerful far and near field illumination with impressive LED lighting technology; combining high optic efficiency with even light distribution and a glare-reducing reflector design. Available in a variety of performances, shapes and beam patterns, these robust and compact lights will lead the way on any journey!

To place your order contact your local branch today. See back page for details.

OSRAM

Light is OSRAM

*Driving lights are ECE compliant and permitted for use on public roads. **Working lights do not have ECE approval and must not be used on public roads. For more information go to: www.osram.co.uk/ledriving-lights. All prices are trade exd. VAT.

NEW EBS7 COMPONENTS FOR SCANIA

In addition to Knorr-Bremse supplying EBS7 Electronic Braking Systems original equipment to Scania Truck applications, a range of serviceable parts for the EBS7 System are now available for the independent aftermarket.

coverage of the various vehicle applications and regional differences. The EBS7 system for Scania applications was first introduced to the OE in 2015 and has been sold more than 195,000 times since.



Knorr-Bremse TruckServices is constantly working to improve its product portfolio and service concepts in line with customer and market requirements to optimise

Still confused? Knorr-Bremse Technical Helpline in Bristol is a available to assist on 0117 9846 222

EBS7 COMPONENTS FOR SCANIA APPLICATIONS

SPEND OVER £500 ON ANY KNORR BREMSE PART AND GET £25 OFF! ASK US FOR DETAILS.



Knorr-Bremse IAM Part Number	Knorr-Bremse OE Part Number	Scania OE Part Number*
Foot Brake Module (FBM) K055628N50	K055628N05	2263181
1-Channel EPM (1Ch) K050214N50	K050214N05	2263182, 2447827, 2653379
2-Channel EPM (2Ch) K125218N50	K050212N05, K050213N05	2263183, 2447828, 2653385, 2263184, 2447829, 2653386, 2447835, 2653387
Trailer Control Module (TCM) K103131N50	K103131N05	2199282
Steering Angle Sensor (SAS) K097326N50	K097326N49 K097326N05	K097326N49, K097326N05

TO FIND OUT MORE CONTACT YOUR LOCAL BRANCH TODAY



FLEETRANNER™ HOSES



Full range of silicone and wire inserted hose also available

45° hoses also available



FLEETRANNER™ GREEN STRIPE STRAIGHT HOSE

This resistant and flexible radiator hose is perfect for general use on straight or slightly bent connections in heavy-duty vehicles. Approved for Marine applications.

FLEETRANNER™ 90° CURVED HOSE

This versatile hose is used for many heavy-duty applications. It is easy to cut to size and to install. Symmetrical 90° curved hoses are frequently used in trucks, buses and tractors or other industrial type applications.

Gates	PN	Ø		ID	L	P	#
		mm	"				
	24212	19	3/4	30	1	6.9	2
	24214	22	7/8	33	1	6.9	2
	24216	25	1	36	1	6.9	2
	24218	29	1 1/8	39	1	6.9	2
	24220	32	1 1/4	42	1	6.9	2
	24222	35	1 3/8	46	1	6.9	2
	24224	38	1 1/2	49	1	6.9	2
	24226	41	1 5/8	52	1	6	2
	24228	44	1 3/4	55	1	5.3	2
	24230	48	1 7/8	58	1	5.3	2
	24232	51	2	61	1	4.2	2
	24234	54	2 1/8	65	1	4.2	2
	24236	57	2 1/4	68	1	4.2	2
	24238	60	2 3/8	71	1	4.2	2
	24240	64	2 1/2	74	1	4.2	2
	24242	67	2 5/8	77	1	4.2	2
	24244	70	2 3/4	81	1	4.2	2
	24246	73	2 7/8	84	1	3.9	2

Gates	PN	Ø		ID	L	R	P	P	P	P	#
		mm	"								
	7022	8	5/16	15	0.300	20	150	5.7	23	3	
	7023	10	3/8	17	0.300	20	150	5.7	23	3	
	7024	12	1/2	19	0.300	20	150	5.7	23	3	
	7025	15	19/32	22	0.300	20	150	5.7	23	3	
	7026	18	11/16	26	0.300	20	150	4.6	19	3	
	7027	22	7/8	30	0.300	30	150	4	16	3	
	7028	25	1	33	0.300	30	150	4	16	3	
	7029	28	1 1/8	37	0.400	30	200	3	12	3	
	7030	30	1 3/16	39	0.400	30	200	3	12	3	
	7031	32	1 1/4	41	0.400	40	200	3	12	3	
	7032	35	1 3/8	44	0.600	40	300	2.8	11	3	
	7033	38	1 1/2	47	0.600	40	300	2.8	11	3	
	7034	40	1 9/16	49	0.600	40	300	2.5	10	3	
	7035	45	1 3/4	54	0.600	50	300	2.5	10	3	
	7036	50	2	59	0.600	50	300	2.3	9	3	
	7037	55	2 3/16	64	0.600	60	300	2.1	8.5	3	
	7038	60	2 3/8	70	0.600	60	300	1.8	7.5	3	
	7041	65	65	75	0.600	65	300	1.8	7.5	3	

Other sizes are available...



FleetRunner™

TO FIND OUT MORE CONTACT YOUR LOCAL BRANCH TODAY!

Grow your battery business

Upgrade to Yuasa

Why settle for good when you can have the best? Upgrade to:

- ✓ A global leader
- ✓ The highest OE quality
- ✓ The widest range
- ✓ Complete support
- ✓ A winning team
- ✓ The best online tools



Discover more at www.yuasa.com



Special Offer! Buy any 2 of 7629 or 7625 and get £5 off each battery!
To find out more contact your local branch today!



Lucas

ELTA



Lighting the way

Whatever guides your fleet, trust Lucas 24v bulbs for dependable performance and reliability.

**LUCAS LLB775 70w 24v
BOX OF 10 LLB775 HEADLIGHT BULBS
only £28.00 + vat**

**To place you order contact us today!
See back page for details.**



Complete Scania Euro 6 Systems



Dinex Sensors



Dinex no: 67031
 OE no: 2294290, 2296800
 Dinex no: 67032
 OE no: 2247381, 2294291
 Type: NOx Sensor



Dinex no: 67042
 OE no: 2301359
 Type: Temperature Sensor

The only ATS unit with both - easily replaceable DPF and DOC without any cutting or welding for the most longevity. The flex-pipes are made from high quality stainless steel, wound and tested to the highest detail contributing to the benefits of replaceable substrates. Direct replacement for OE unit. Dinex also offers all exhaust pipes and other parts related to exhaust system for Scania trucks.



going the extra mile



The exhaust system evolution

System w/SCR (Euro 4-5)

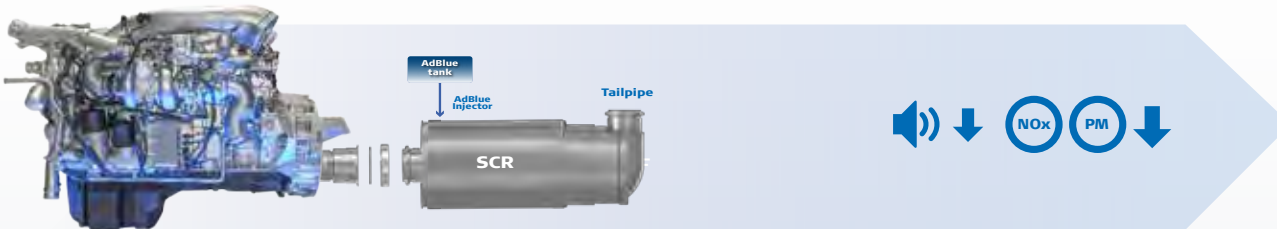

System w/DOC + DPF + SCR (Euro 6)

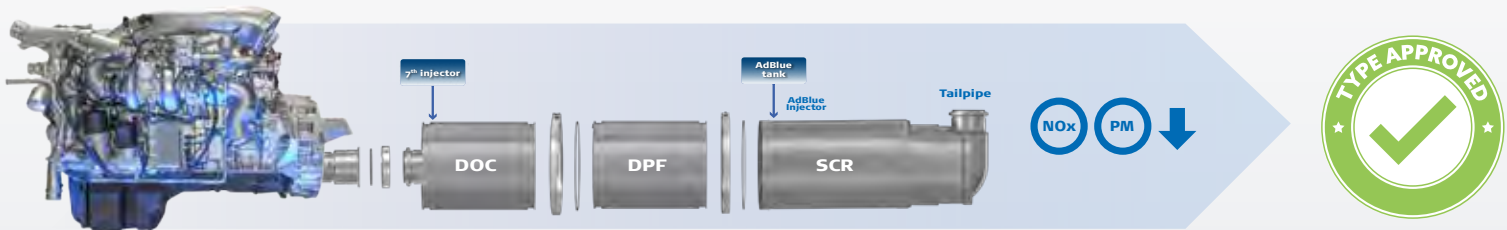

See our new Catalogue at dinex.net/downloads/trucks or scan QR code with your smartphone



CHECK OUT OUR NEW EURO 6 CATALOGUE



You're safer with us

Brigade is at the pinnacle of commercial vehicle and mobile plant blind-spot safety, a founder and innovator of market leading safety devices for over 40 years.



Direct Vision Standard
New regulations in force
as of 01-03-21!

Direct Vision Standard Safe System Kit

6079 - DVS-SS-01

Direct Vision Standard for rigid vehicles



Kit Includes:

1. Select range 7" Digital LCD Monitor
2. Select range flush mount side - view camera
3. Select camera 5 metre cable
4. Sidescan® sensor system
5. Low speed trigger module
6. Turn Indicator Trigger ECU
7. Speaking alarm
8. Latched cut-out switch for speaking alarm
9. Blind spot Take care DVS sticker

Essential Camera Monitor Kit

5774 - VBV-670-000

PAL Camera Monitor System



Kit Includes:

1. Essential Range Monitor
2. Essential Range Camera
3. 20m Extension Cable

Scania Camera Monitor Adapter

5318 - AC-069

Select Camera to Scania Monitor/Infotainment system



NO.1 FOR HEAVY METAL

TAM
TRUCK AXLE MODULES



TRB
TAPERED ROLLER BEARINGS



THU
TRUCK HUB UNITS



RIU
REPAIR INSERT UNITS



SmartSET
TRB REPAIR SOLUTIONS



FAG



Whatever the application, FAG has a quality hub repair solution for you. FAG is a trusted technology partner and original equipment supplier of precision bearings to the automotive, engineering and aerospace industries. Our commercial vehicle hub repair solutions provides the most innovative, technically advanced and high quality range of bearings for trucks and trailers in the aftermarket.

www.repxpert.co.uk
aftermarket.schaeffler.co.uk

SCHAEFFLER

Scania 3,4,5,6 Series Front Cartridge Bearings 571762.01.H1

ONLY £125.00 EACH or £5.00 OFF WHEN YOU BUY TWO

PRESTOLITE ROTATING ELECTRICS

THE ONLY UK MANUFACTURER OF STARTERS & ALTERNATORS

**ORIGINAL EQUIPMENT SUPPLIER TO THE EUROPEAN TRUCK INDUSTRY
AND 'THE ONLY UK MANUFACTURER' OF STARTERS & ALTERNATORS.**



Prestolite is an Original Equipment manufacturer to more than 40 European vehicle and engine manufacturers including Scania.

best option for high quality, reliability and price. The same knowledge, expertise and processes are used to manufacture both OE and aftermarket products.

The company's aftermarket range not only includes replacements for Prestolite original equipment units but also for Mitsubishi and Bosch and will guarantee operators the

All truck starters and alternators are brand new, not reconditioned with **no hidden surcharges or old core** to return.

NEW TO RANGE STARTERS AND ALTERNATORS

AVI150P2114HP: 24V 190A alternator for Scania R-Series Truck

OE ref: 2448165,
2853478, 2905970,
2572595, 2920858,
0570718



861079: 24V 100A alternator

OE ref: 0570884,
0571439, 571613,
1504314, 1504316,
1774595, 1777299,
1777464, 2395907,
2398366,
A004TR5491



**NEW
PRODUCT**

CALL FOR
OUR BEST
PRICES!

861298: 24V 100A alternator

OE ref: 0570887,
573015, 01888010,
0570887, 1475569,
1884268, 2398368,
A004TR5691



860805GB: 24V 110A alternator

OE ref: 0518064,
0571614, 1442788,
1475570, 0986047820



CALL FOR
OUR BEST
PRICES!



CALL FOR
OUR BEST
PRICES!

M90R3545SE: 24V 6kW starter

OE ref: 1447911,
1796026, 2031368,
2148650, 2276131,
2708317, 0571467,
0573507, 0579261,
0579265, 0579271
0986021480



M105R3527SE: 24V 7.5kW starter

OE ref: 1797880,
2008268, 579270,
M009T83771,
0986022250



CALL FOR
OUR BEST
PRICES!

Contact your local branch for more details about our full range of aftermarket rotating electrics.

Prestolite
electric

PERFECT PARTNER FOR YOUR FLEET



NEW TEXTAR CV DISC RANGE

Part Number 93088300 Scania Textar front & rear brake discs.



Part number 2933101 Textar T3050 OE truck material brake pad.



Part number 2933102 Textar T7400 Bus & Coach Material.

FULL CV DISC RANGE NOW AVAILABLE



**MORE THAN JUST A CATALOGUE –
IT'S EASY TO FIND THE RIGHT PARTS.**

Raufoss New Line Push-in Air Brake Fittings

- A versatile selection of components which assemble together to form a comprehensive range of fittings for many applications.
- New composite material reduces system weight
- Reduced article numbers, increased design flexibility
- Releasable tube & fittings

Assorted Box - No. MSK802

- Fast moving parts
- Great starter kit
- Release tools

**Only
£110**



Our range includes



Call your local IFA member to order, Or for a copy of this handy wall chart



Assorted Box - No. MSK805

- Fast moving parts
- Great starter kit
- Release tools

**Only
£195**



OE fitment as standard on a number of the world's top Truck/Bus manufacturers including Renault, Mercedes, Scania, Volvo & Optare



PULL OUT AND KEEP • PULL OUT AND KEEP • PULL OUT AND KEEP • PULL OUT AND KEEP • PULL OUT AND KEEP

Advanced Commercial Lubricants

The most advanced technologies.
The highest quality base oils.

The AD range of commercial lubricants has been developed using the most advanced technologies and highest quality base oils available. Commitment to cutting edge research and stringent product testing guarantees that AD commercial lubricants surpass the ever evolving demands of the world's leading engine and driveline manufacturers. The full range of products include engine oils, gear oils, ATFs, hydraulic oils and grease. Contact your local supplier for further details.



AD COMMERCIAL ENGINE OILS

Product Code	Product Name	Fully Syn	Semi-Syn	Mineral	ACEA	API	Allison	Cummins	DAF	Detroit Diesel	Deutz	Iveco	JASO	MAN	MB	Renault	Scania	Volvo
005	Ultra Eco Plus 5W-30	✓			E4, E6, E9, E7	CK-4		CES 20086 CES 20081		93K222 93K218	DOC IV-18 LA	18-1804 TLS E6	DH-2 DH-1 DL-0	M3777 M3677	228.52 228.51 228.31	RLD-4 RLD-3	LDF-4 LA	VDS-4.5
010	Ultra Eco 5W-30	✓			E6, E9, E7	CJ-4 SN		CES 20081			DOC IV-10 LA		DH-2	M3677 M3477 M3271-1	228.51 228.31 235.28	RLD-3 RLD-2 RXD, RGD	LA	VDS-4 VDS-3 CNG
020	Ultra Euro Plus 10W-40	✓			E6, E9, E4, E7	CK-4		CES 20086 CES 20081		93K222 93K218	DOC IV-18 LA	18-809 NG2	DH-2 DH-1 DL-0	M3477 M3775 M3271-1	228.52 228.51 228.31	RLD-4 RLD-3	LA	VDS-4.5
030	Ultra Long Drain 10W-40	✓			E7, E4	CF		CES 20072	Extended Drains		DOC III-05			M3277	228.5	RXD, RLD, RLD-2, RD-2	LDF-3 LDF-2 LDF	VDS-3
040	Ultra Euro 10W-40	✓			E6, E9, E7	CI-4		CES 20076/77	Extended Drains		DOC IV-10 LA DOC III-10 LA DOC III-10		DH-2	M3477 M3271-1	228.51	RXD, RLD-2 RGD		VDS-3
050	Ultra E9 15W-40			✓	E9, E7	CK-4 SN	TES 439	CES 20086		DFS 93K222	DOC III-10 LA		DH-2	M3775 M3575	228.31	RLD-4 RLD-3		VDS-4.5
060	Ultra E9 10W-30			✓	E9, E7	CK-4		CES 20086		DFS 93K222	DOC III-18 LA		DH-2	M3775 M3575	228.31	RLD-4 RLD-3		VDS-4.5
065	Premium UHPD 5W-30	✓			E4	CH-4			HP-2					M3277	228.5	RXD		VDS-2
070	Premium Long Drain 10W-40			✓	E7, E4 A3/B3 A3/B4 E7	CI-4								M3277	228.5	RXD		VDS-3
080	Premium E7 15W-40			✓	A3/B3 A3/B4 E7	CI-4/ SL CF	C4	CES 20071/72 CES 20076/77 CES 20078		DDC 93K215	DOC III-10		DH-1	M3275	228.3 229.1	RLD-2		VDS-3

AD COMMERCIAL GEAR OILS & TRANSMISSION FLUIDS

Product Code	Product Name	Fully Syn	Semi Syn	Mineral	API	SAE	Allison	Eaton	Ford	GM	Iveco	MAN	MB	Scania	Voith	Volvo	ZF
400	Fully Synthetic 75W-80	✓			GL-4			300,000 km or 3 years				341 Type Z-4, Z-3 Z-2 & Z-1, 341 Type E-3 E-2 & E-1 341 ML, 341 N	235.4			97307 97305	TE-ML OIL, 02A 02B, 02D, 02E, 02L 08, 16K
405	Super Pro Gear 75W-90	✓			MT-1 GL-5 GL-4	J2360					Extended Drain	3343 S 342 Type SJ, M3 341 E3, Z2	235.8	STO 2:0A FS		97312	TE-ML 02B, 05B,07A,08,12B 16F,17B,19C,21F
410	Fully Synthetic 75W-90	✓			GL-5 GL-4												
415	Super MB 75W-90	✓			GL-4								235.11				
420	Semi Synthetic 75W-90		✓		GL-5 GL-4												
425	Semi Synthetic 75W-80		✓		GL-5 GL-4												
430	HD 80W-90			✓	GL-5 GL-4												
435	Super HD 80W-90			✓	MT-1 GL-5 GL-4	J2360						M3343 Type M 341 Type E-2	235.0	STO I:0 STO II:G			TE-ML 02B, 05A,07A,08,12E 12M,16B,16C,16D 17B,19B,21A
480	HD 85W-140			✓	GL-5 GL-4												
485	Super HD 85W-140			✓	MT-1 GL-5 GL-4	J2360								STO I:0			05A,07A,08 12E,12M,16B,16C 16D,17B,21A
500	Auto MVA	✓					C4 TES-295		Mercon Mercon V	Dexron IIIH		339 V1 339 Z1 339 Z2	236.9		H55.6335	97341 97340	TE-ML 03D, 04D 14A,14B,16L,17C
505	Auto ELC	✓					C4 TES-295		Mercon V	Dexron IIIH		339 V1 339 Z2 339 Z3	236.9, 236.7 236.6, 236.5 236.2, 236.1		H55.6336 H55.6335	97341 97340	04D, 05L, 09, 11A 11B, 14B, 14C, 16L 16M, 16S, 20C, 20F, 25C
510	Auto VI Fully Synthetic	✓					C4		Mercon	Dexron VI			236.5		H55.6335	97340	TE-ML 09
520	Auto III Semi Synthetic		✓				C4 TES-389		Mercon	Dexron IIIH		339F 339 V1 & Z1 339 V2 & Z2	236.10, 236.9 236.8, 236.7 236.6, 236.5 236.1		H55.6335	97341 97340	TE-ML 02F, 03D,04D,09 11A,11B,14A 14B,16L,17C

Tables to be used as a guide only – if unsure of the application, please contact your local supplier.

The above tables cover a selection of the range available, contact your local supplier for details of the full range of AD commercial lubricants.

*AD branded commercial lubricants can be used without invalidating the manufacturer's warranty, providing the lubricant specification required by the vehicle manufacturer is detailed on the product label or Technical Data Sheet.



Protect your investment



AD Lubricants surpass the ever-evolving demands of the world's leading engine & driveline manufacturers. Cutting-edge research & stringent product testing guarantee it.



ZF Aftermarket for Commercial Vehicles

World's market leader in commercial vehicle drivetrain, chassis, steering, suspension and braking products.

In Focus: Scania, popular references

	Part Number	OE Number	Model
	3400 700 612	574917, 574979, 574000	L,P,G,R,S,T - series
	3400 700 663	2399802, 574988	L,P,G,R,S,T - series
	3400 700 610	574919, 574916	L,P,G,R,S,T - series
	3400 700 491	574920	P,G,R,T - series
	21009 01	1769597, 1384027	4 - series P,G,R,T - series
	21455 01	1759691, 1343283	4 - series P,G,R,T - series
	21456 01	1759690, 1343266	4 - series P,G,R,T - series
	36655 01	1733471, 2007279, 1747467	4 - series P,G,R,T - series
	37247 01	2853196, 2161883, 2584263, 2113903, 040390526592-01, 040360526592-02,	4 - series P,G,R,T - series
	19866 01	395350, 1397866	114, 124, 4 - series P,G,R,T - series

Get the **ZF Part Finder app**. Available from the App Store and Google Play Store.



aftermarket.zf.com





SCANIA P, G, R, T – Series P 230, R 230 Mounting Instructions

Clutch removal/installation

Required special tools

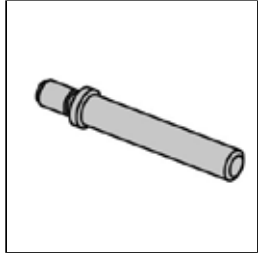

Centring mandrel
OE (99 204)

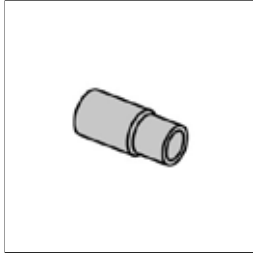

Centering mandrel
adapter
OE (99 205)

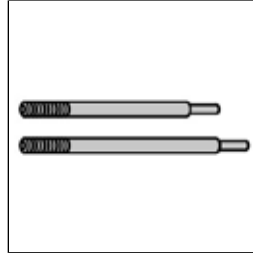

Guide pin(s)
OE (98 747)



4200 080 562
Clutch alignment tools
FROM ONLY £533.89

Remove

Remove gearbox.

- Unscrew opposing bolts. (1)
- Screw in guide pin(s). (2)
- Complete special tool(s). (3)
- Fix clutch drive plate using centering tool.

Required special tools

- Guide pin(s) (2) OE (98 747)
- Centring mandrel OE (99 204)
- Centering mandrel adapter OE (99 205)
- (see figure 1)

Unscrew remaining pressure plate screws.

- Remove clutch pressure plate. (1)
- Degrease clutch drive plate. (2)
- (see figure 2)

Install

Installation is carried out in reverse order of removal.

Gradually tighten clutch pressure plate screw(s) cross-wise. (see figure 3)

Lubricate hub splines of clutch disk and gearshaft lightly with molybdenum grease, wipe off excess grease.

Install gearbox.

Figure 3. Clutch Cover



Always tighten new bolts alternating crosswise to avoid distorting cover during installation

Figure 1

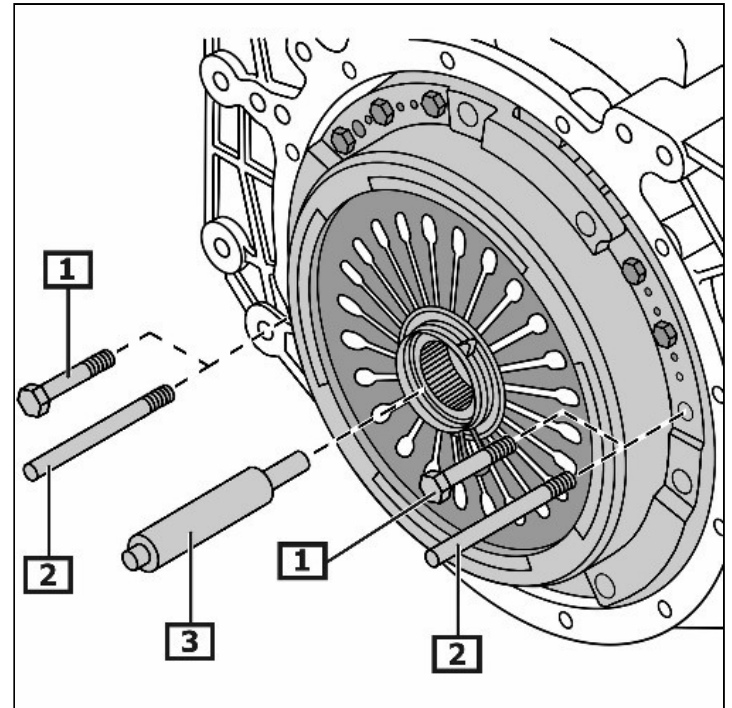

1 Clutch pressure
plate screw(s)

2 Guide pin(s)

3 Special tool

Figure 2

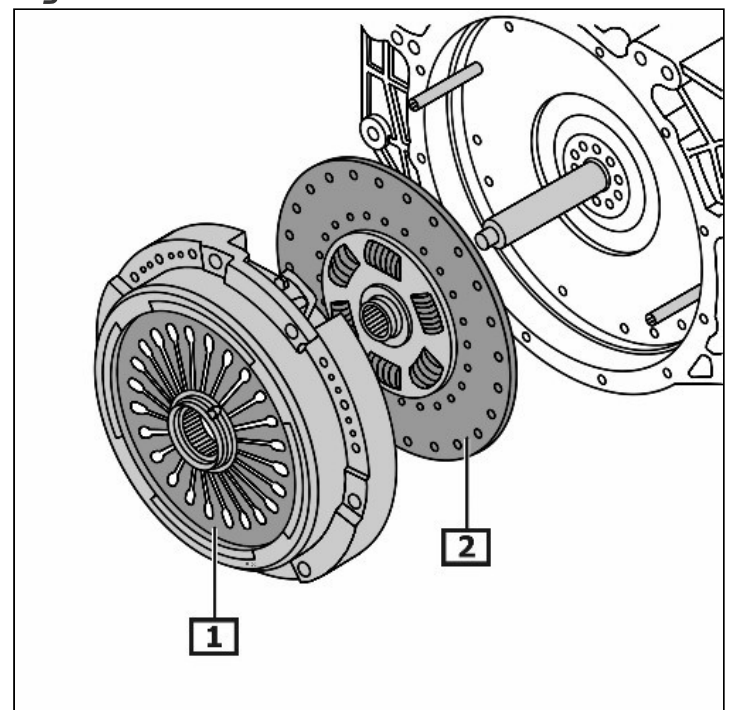

1 Clutch pressure
plate

2 Clutch drive plate

For more information contact your local branch

AutomInt LIMITED

IFA2NDQTR21



SCANIA— Complete Cab Mount Assemblies



O/E Number : 2023667

Automint Number : CM018



O/E Number : 2291738

Automint Number : CM019

SCANIA— Air Springs



O/E Number : 1774804

Automint Number : 41275



O/E Number : 1319761

Automint Number : 04055

SCANIA— Shock Absorbers



O/E Number : 1867874

Automint Number : SA0350Ti



O/E Number : 1519631

Automint Number : SA0353Ti

- * Exceptional expertise
- * Widest Range
- * Second to none service & technical advise.



For all your SCANIA suspension requirements, please contact your local branch for more details!

STAR BUY!

Buy a pair of any of the products featured and get £5 off each item.

WINNARD

150 YEARS OF ENGINEERING EXPERIENCE

DOES YOUR BRAKE DRUM SUPPLIER CHECK THE QUALITY OF THE PARTS THEY SUPPLY YOU?



WINNARD has been manufacturing brake drums for over 90 years. We have the knowledge, experience, quality control procedures and engineering technology to ensure our parts meet the quality standards required for such safety-critical components.

You cannot judge product conformity by appearances alone. The correct dimensional characteristics are critical to ensure safe operation. You can count on WINNARD to supply you safe effective braking products.

Look for the WINNARD name on your braking products



Failed aftermarket Scania drum ref; DVSA investigation Jan 20

GREAT DEALS ON THESE POPULAR SCANIA PARTS

All our Brake Discs are manufactured to our specification by ISO TS16949 accredited factories with many references having ECE R90 approval. During the design process we also make enhancements over the Original Equipment part. These enhancements include improvements to the disc's thermal fatigue capabilities as well as reductions in corrosion of critical areas such as ABS teeth.

**SPECIAL OFFER!
£5 OFF WHEN YOU BUY IN PAIRS!**



SC1023S Solid Disc



SC1023 Vented Disc

TO FIND OUT MORE ABOUT THE ENTIRE WINNARD RANGE ASK YOUR LOCAL BRANCH!

MAHLE

MAHLE THERMAL MANAGEMENT

QUALITY THAT STANDS OUT
MAHLE THERMAL PREMIUM LINE



MAHLE offer a full range of products and services for engine cooling and air conditioning available through your local **IFA distributor**.

For an unbeatable deal contact your local branch today!

WWW.MAHLE-AFTERMARKET.COM
WWW.MPULSE.MAHLE.COM

PREMIUM
LINE



LED VEHICLE LIGHTING

**EXCLUSIVELY DESIGNED
EXPERTLY MANUFACTURED**



UTILITY RANGE

15W SQUARE WORK LAMP

12/24V multivolt
Flood beam
ECE R10 approved
1200 raw lumens
IP67 ingress protection

NOW ONLY **10915BM**
£13.00 ex VAT.

MAGNETIC REAR LAMP TRAILER WIRING KIT
with 7m cable and 7-pin plug

12 Volt
IP67 - whole system protection
ECE approved

NOW ONLY **99ARL2-AWK7M**
£44.95 ex VAT.



FRONT/REAR RUBBER MARKER LAMP
with integrated Side Marker

12/24V multivolt
ECE approved
IP67 ingress protection
Impact resistant rubber housing

NOW ONLY **1005RWM**
£15.98 ex VAT.



Side Marker Lamp

12/24V multivolt
ECE approved
IP67 ingress protection

NOW ONLY **44AME**
£9.00 ex VAT.

Watch our product demonstration videos on [YouTube](#) "LED Autolamps Europe"

FOR MORE LIGHTING AND ELECTRICAL PRODUCTS ASK IN BRANCH FOR OUR COMPREHENSIVE PARTS CATALOGUE OUT NOW!

Service Kits available at great prices! Ask us for details!



SCANIA G-P-R-T Series

Built for the road, to endure & perform. **Donaldson filters keep you moving.**

MODEL	ENGINE	AIR	OIL / LUBE	FUEL	POWER-STEERING	TRANSMISSION	CABIN	OTHER
G Series	DC/DT/OC	P953213	P953329 (CR)	P551855 (FWS)	P550309	P761108	P957866	P951419 (AD)
		P778335	P550490 (SO)	P550628 (CR)			P753338	X770733 (UF)
	
P Series	DC/DT/OC	P953211	P953329 (CR)	P955607 (FWS)	P550309	P761108	P957866	P951419 (AD)
		P953213	P550490 (SO)	P550653 (CR)			P786611	X770733 (UF)
	
R Series	DC/DT	P953210	P550220 (CR)	P955607 (FWS)	P550309	P761108	P957866	P951419 (AD)
		P778336	P550490 (SO)	P550653 (CR)			P786611	X770733 (UF)
	
T Series	DC/DT	P778335	P550220 (CR)	P550653 (CR)	P550309	P761108	P786611	P951419 (AD)
		P784457	P550490 (SO)	P551856 (SO)				...
	

... More Options Available | AD: Air dryer | CR: Cartridge | FWS: Fuel water separator | SO: Spin-on | UF: AdBlue

To find out more contact your local branch today! See back page for details.

BRAKING NEWS



With growing demand for the tried and tested Intradrum from our SAF Fleet customers and SAF parts distributors, we've put together a genuine SAF axle Brake shoe reline kit to make relines as simple and efficient as possible. Our SAF reline kit is a direct OE replacement and ensures maximum efficiency and safety from SAF OE original parts. Retaining that class-leading braking performance that is required in the modern transport industry.

3.434.3653.00 Brake Shoe Kit Part number,
for the S9-4218 Axle which has 420 x 180 brake shoes.
Known as SJ28/29 shoes.

This kit comprises of the following:

4 x lined shoes (including rollers): 3055012000 - no surcharge, fully reline-able metalwork.
2 x Return springs: 1447005801 2 x Spring clamps: 1151000800

3.434.3655.00 Brake Shoe Kit Part number,
for our low-loader axles Z9 / Z11 range that take the 300 x 200 brake shoes. Known as SJ22/23 Shoes

This kit comprises of the following:

4 x lined shoes (including rollers): 3055012901 - no surcharge, fully reline-able metalwork.
2 x Return springs: 144700600 2 x Spring clamps: 1151001300

3.434.3617.00 Brake Shoe Kit Part number,
for the S9-3718 Axle which has 367 x 180 brake shoes.
Known as SJ32/33 shoes.

This kit comprises of the following:

4 x lined shoes (including rollers): 3055012600 - no surcharge, fully reline-able metalwork.
2 x Return springs: 1447005801 2 x Spring clamps: 1151000800

MORE BRAKING NEWS

Leading on from the introduction of the new SAF Caliper for the 22.5" disc brake. The **SBS2220H01** now replaces the **SBS2220H0**. The advantages are, optimized cast parts, weight reduction (approx. 5kg per axle) and the optimised brake pad retaining bracket.

The new part number for **SBS2220H01** brake pads is 03 057 001500, this comes complete with the new retaining bracket.

Part numbers for replacement calipers are as follows:

Left hand 03080009700

Right Hand 03080009800

SAF PADS THAT WON'T "BRAKE THE BANK"

Offering OE quality at an aftermarket price, we now offer 01 versions of the 3 most popular pads. **3057009601, 3057008501, 3057007701**

Are all now available with the peace of mind and guarantee you get from specifying OE without the cost.

Check availability and purchase at your preferred local SAF-Holland stockist.

If you have any technical questions, please contact the IMS Group directly and we will endeavour to assist you.

SAF-AXLE COMPLETE AXLE RELINE KITS



3.434.3653.00



3.434.3655.00



3.057.0015.00



3057009601



3057008501



3057007701

MORE INFO

For more information, please contact: **T** +44 (0) 7881 957334 | **E** mark.prophet@imslimited.com
IMS Group Trans Tech House Shephed LE12 9NH | **T** +44 (0)1509 600 185 | **W** www.imslimited.com



www.dayco.com

Dayco Heavy Duty.

Your global partner from **OE** to
the **Aftermarket**.

KUBELIBRE.COM



Made for Scania



10PK2220HD
MULTI GROOVE BELT



APV2729
TENSIONER



APV2736
TENSIONER



APV3064
IDLER ROLLER

Leader in engineering and production of OE HD tensioners. OE HD belts designed for diesel grade HD applications. High performance and reliability. The preferred partner of the most important OE truck brands and engine equipment. VOLVO, CNH-IVECO, MERCEDES, MAN, SCANIA, CUMMINS, CATERPILLAR.

DAYCO®

MOVE FORWARD. ALWAYS.™



@DuriteLimited durite.co.uk

BE PREPARED WITH DURITE ESSENTIAL EMERGENCY KIT

42,000mAh, 1500A Booster | 0-649-40

- ✓ Starts 12V & 24V vehicles up to 16.0L
- ✓ 3W LED sos/work light

ONLY £195.00

Rechargeable LED Warning Flares | 0-446-60

- ✓ Up to 60 hours burn time, with 9 Flash patterns
- ✓ Strong magnetic base easily fixes to vehicle

ONLY £120.00

Contact your local branch today!

THE TRUSTED QUALITY BRAND FOR PROFESSIONALS



Scan the QR code to see the flares in action



TRANSFORMING COMMERCIAL VEHICLE & PSV MAINTENANCE AND INSPECTION

WORKING & MAINTENANCE PITS

INSPECTION & TEST PITS

WASHDOWN PITS & RAMPS

PremierPits
PREFABRICATED VEHICLE PITS

Premier Pits – The UK's No.1 Prefabricated Pit Company supplying the Commercial Vehicle & PSV industries for 40 years. Improve the efficiency of your workshop with our range of inspection pits and washdown solutions, built to the highest CE certified standards.

FINANCE OPTIONS AVAILABLE WITH TAX RELIEF EXAMPLE

A 12m Premier Working Pit, fully installed by our professional team*
from **£660.00 ex VAT per month**
Total net cost after tax relief - approx £19,240.00 ex VAT**

*Price is for a standard 12m Premier Working Pit. Full installation includes excavation and price is subject to site survey. Other installation options available. T & C's apply.

**Finance example based on a 3 year term, subject to status and correct at time of print. Tax relief based on 19%.

To find out more contact your local branch



Scania O.E. Euro 6

O.E. INNOVATIONS FOR THE AFTERMARKET

- O.E. pedigree*
- TH Damper innovation available for an uncompromised cabin comfort
- 2 years warranty unlimited mileage in Europe**
- Available on all main commercial vehicles applications



Ref	Description	NE/SE	Component	Euro 6	Model
827494	KIT SCANIA DC13 EURO 6 REMAN	Reman	Clutch Reman Kit	Euro 6	P, G, R, T Series 13-
827492	KIT SCANIA DC09 EURO 6 REMAN	Reman	Clutch Reman Kit	Euro 6	P, G, R, T Series 13-
827295	KIT 430 DTE SCANIA NEW	New	All Kit	Euro 6	P, G, R, T Series 04-
827493	KIT SCANIA DC 13EURO 6 NEW	New	All Kit	Euro 6	P, G, R, T Series 13-
827296	KIT 430 DTE SCANIA REMAN	Reman	Clutch Reman Kit	Euro 6	P, G, R, T Series 04-
827495	KIT SCANIA DC16 EURO 6 NEW	New	All Kit	Euro 6	P, G, R, T Series 13-
827496	KIT SCANIA DC16 EURO 6 REMAN	Reman	Clutch Reman Kit	Euro 6	P, G, R, T Series 13-
827561	CLUTCH KIT 3P NEW 430 O.E. SCANIA	NEW	CLUTCH KIT 3P	Euro 6	SCANIA DC09 EURO 6
827562	CLUTCH KIT 3P REMAN 430 SCANIA	Reman	CLUTCH KIT 3P	Euro 6	SCANIA DC09 REMAN
827580	CLUTCH KIT 3P REMAN 430 SCANIA	Reman	CLUTCH KIT 3P	Euro 6	SCANIA P EURO 6
827579	CLUTCH KIT 3P NEW 430 OE SCANIA	NEW	CLUTCH KIT 3P	Euro 6	SCANIA P EURO 6

*279 kits are O.E. Clutch manufactured by Valeo
65 kits are matching quality manufactured by Valeo
10 kits are not manufactured by Valeo

**Warranty is applicable in European Union 28 countries added by Norway, Iceland, Switzerland, Macedonia, Montenegro, Serbia, Bosnia, Albania and Kosovo for truck clutch applications (diam.>267 mm) under normal conditions of use and service. For more information please contact your local dealer or refer to Valeo Service General terms and conditions

SMART TECHNOLOGY FOR SMARTER MOBILITY

www.valeoservice.co.uk

TECHNICAL HOTLINES

NEED SOME ADVICE TO FIT A REPLACEMENT PART? OR HELP FINDING IT? OUR COMPREHENSIVE CHECKLIST PUTS ALL THE CONTACT DETAILS FOR THE SUPPLIER YOU NEED AT YOUR FINGERTIPS!



AUTOMINT  T 01484 903 015 e technical@automint.uk w www.automint.uk	FIRST LINE BORG & BECK  T 01869 329 709 e cv@borgandbeck.com	KNORR BREMSE  T 0117 9846 222 e technical@knorr-bremse.com w www.knorr-bremse.com	PRESTOLITE  T 020 8231 1137 e eu_info@prestolite.com w www.prestolite-eu.com	TECALEMIT  T 01752 219100 w www.tecalemit.co.uk/ equipment-we-supply
BESTPLATE  T 01253 475217 e technical@bestplate.com w www.bestplate.com	FREIGHT PRODUCTS (UK) LTD  T 01926 641 222 e sales@freightproducts.co.uk w www.fpluk.com	LASER TOOLS  T 01926 818181 e technical@toolconnection.co.uk w www.toolconnection.co.uk	QUADRALENE  T 01332 292500 e sales@quadralene.co.uk w www.quadralene.com	THERMOBILE  T 02476 357960 e sales@thermobile.co.uk
BOYDELL & JACKS  T 01282 456411 e sales@featherwing.com	GATES  T 0844 980 0062 e info@gatestechzone.com w www.gatestechzone.com	LED AUTOLAMPS EUROPE  T 0121 313 2222 e enquiries@ledautolamps-uk.com w www.ledautolamps-uk.com	RING  T 0113 2137329 w www.ringautomotive.com	TMD FRICTION UK  T 03300 583908 e uk.technical@tmdfriction.com w www.textar.com
BRIGADE  T 01322 420300 e technical@brigade-electronics.com w https://brigade-electronics.com	GEMCO  T 01604 828600 e sales@gemco.co.uk w www.gemco.co.uk	LIFTMASTER  T 01420 549037 e service@liftmasterltd.com	ROADLINK INTERNATIONAL  T 01902 636206 w www.roadlink-international.co.uk	UNIVERSAL COMPONENTS  T 01142 611122 e sales.uk@ucgroup.com w www.ucukltd.com
BTN TURBO  T 0117 428 8107 e technical@bnturbo.com w www.bnturbo.com/turbotech/	GRANNING  T 01925 810 400 e sales.uk@granninglynx.com w www.airsprings.com	LUCAS  T 01675 437 429 e techassist@elta.co.uk w www.lucaselectrical.co.uk/ engine-management.html	SACH'S  T 0333 240 1123 e info.zf-services-uk@zf.com w www.aftermarket.zf.com/uk	VALEO  T 01527 838 300 (Option 2) e vsa.uk.technical.mailbox@valeo.com
DAYCO  e info.uk@dayco.com w www.daycoaftermarket.com	GYS  T 01926 338609 (main number) tech guide to working safely with batteries: www.gys-welding.com	LUMAG  T 07734 694150 (Colin Smit) e c.smit@lumagltd.co.uk w www.lumag.pl	SCHAEFFLER  T 01432 264264 e aftermarket.uk@schaeffler.com w www.repxpert.co.uk	VEGE UK  T 01246 245945 e aftersales@vegeuk.com
DINEX  T 01925 849 849 e dinex@dinex.co.uk w www.dinex.co.uk	HALDEX  T 01325 311234	MAHLE  T 0845 688 5007 w www.mahle-aftermarket.com/eu/en/services/technical-messenger/ MPulse (Online Mag for Garages): www.mpulse.mahle.com/en/	SCM TURBOMOTIVE LTD  T 01484 345 345 e info@scmturbo.com w www.scmturbo.com	WABCO  T 01924 595555 e info.uk@wabco-auto.com w www.wabco-customercentre.com
DONALDSON FILTER COMPONENTS  T 01482 832607 w www.donaldson.com/en-be/	HAMMER CLUTCH  T 01922 720910 e sales@hammerclutch.co.uk w www.hammerkupplungen.com	MISWA  T 01604 701111 w www.miswa.com	SEALEY  T 01284 757505 w www.sealey.co.uk	WINNARD  T 01709 712000 e sales@winnard.co.uk w www.winnard.co.uk
DRAPER TOOLS  T 02380341615 e sales@drapertools.com w www.drapertools.com	HELLA  T 01295 662400 w www.hella.com/techworld/uk/	PREMIER PITS  T 01775 821 222 e info@premierpits.com w www.premierpits.com	SIP  T 01509 500400 e technical@sip-group.com w www.sip-group.com/page/techzone.aspx	WYNN'S  T 02476 472634 e helpline@wynns.uk.com w www.wynns.uk.com
FEBI  T 01246 479081 e fen-technical.sales@bilsteingroup.com w partsfinder.bilsteingroup.com	IMS (SAF)  T 01509 600 185 e info@imslimited.com w www.imslimited.com	SKF  T 01582 496334 e helpline@skf.com e www.vsm.skf.com	YUASA  T 01793 833 555 e info@gs-yuasa.uk	FENTEX  T 01487 823184 e orders@fentex.co.uk w www.fentex.co.uk

LASER[®]

THE RIGHT TOOL FOR EVERY JOB!



FRONT HUB NUT SOCKET 80mm - FOR SCANIA

- 80mm (Driven by 41mm Hex).
- Eight sided.
- Specifically for front hub nut.
- Suitable for Scania trucks.
- Equivalent to OEM 99307.

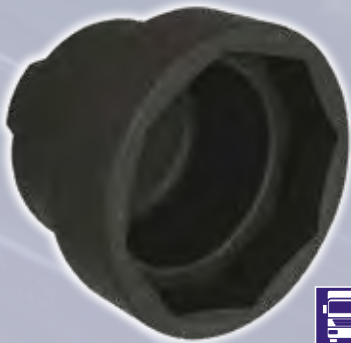

4400



ONLY £99.95

REAR HUB NUT SOCKET ¾" D 100mm - FOR SCANIA

- ¾" D x 100mm.
- Specifically for removing the rear hub nuts.
- Suitable for Scania HGV's.
- Manufactured from robust quality carbon steel.



4563



ONLY £109.95

RADIATOR QUICK COUPLER - FOR SCANIA

- Quick coupler for filling radiators on HGVs.
- Knurled connector for ease of use.
- Manufactured from steel with chrome finish.



5077



ONLY £39.95

CRANKSHAFT ROTATOR ½" D - FOR SCANIA

- Applications: Scania trucks manufactured after 1996.
- Manufactured from carbon steel with black phosphate finish.



6331



ONLY £26.95

REAR SPRING SHACKLE PIN SOCKET ¾" D - FOR SCANIA

- Size: 34mm x 46mm x ¾" D
- Applications: Scania
- Manufactured from chrome molybdenum.
- Total length: 50mm



6898



ONLY £39.95

HUB COVER SOCKET - 8 SIDED 85mm

- Applications: Scania Hub Nut Socket.
- 85mm across flats, 8 sided
- 1" D
- Impact quality; power tool safe.



7675

ONLY £89.95

DIESEL INJECTOR SOCKET - WINDOW ½" D 28mm

- Applications: Scania & Volvo HGV.
- Bi-Hex (12pt) x 28mm.
- With access window, allowing the socket to easily fit over the injector.
- Manufactured from Chrome Vanadium.



3299

ONLY £14.95

OFFSET SLOGGING SPANNER 26mm

- Size: 26 x 247mm long
- Industrial quality.
- Manufactured from chrome vanadium with black finish.
- Part of a range of offset slogging spanners from 24mm to 115mm.



6334

ONLY £36.95

CALL YOUR LOCAL BRANCH TODAY

CV SMARTCHOICE FROM

PICKSONS

TRUCK TRAILER & BUS PARTS

AVONMOUTH
01179 821321

BRIDGWATER
01278 450152

BROMSGROVE
01527 833822

GLOUCESTER
01452 757500

SWINDON
01793 822922

YATE (HEAD OFFICE)
01454 311848