

CV **SMARTCHOICE** FROM

# PICKSONS

TRUCK & TRAILER PARTS

ISSUE 18 + APRIL – JUNE 2019 + All offers end 30 April 2019 and are subject to availability. All prices exclude VAT.

# HEAVYWEIGHT STOPPING POWER!

New-to-range from Haldex:  
The Grau 24/30 Brake Chamber



PLUS...

**WIN FREE WEEKEND TICKETS  
TO CONVOY IN THE PARK**  
SEE INSIDE FOR DETAILS...



Also in this issue...



**GATES  
COOLRUNNER™  
BELTS** – driving profit  
opportunities for workshops



**SPOT THE  
DIFFERENCE** – not all  
alternators are the same...



**INDIRECT  
INTERCOOLERS**  
What they are and how  
they work...



THE LEADING AUTOMOTIVE PARTS DISTRIBUTOR IN EUROPE

# COMMERCIAL VEHICLE SMARTCHOICE

## Focus on DAF

6 Carwood

6 Donaldson

7 Dayco

13 Prestolite

### Also inside this issue

- |                         |                                  |                             |
|-------------------------|----------------------------------|-----------------------------|
| 2 Ring                  | 10 Haldex / FAG                  | 16 Knorr-Bremse / Trucksafe |
| 3 Lucas Lighting        | 11 Tech Talk: Behr Hella Service | 17 Mahle                    |
| 4 Gates / LED Autolamps | 12 BPW                           | 18 Draper / Wabco           |
| 5 Febi                  | 13 Textar Competition            | 19 Tecalemit                |
| 8 Saville               | 14 Featherwing / BTN Turbo       | 20 Winnard                  |
| 9 TMD Friction          | 15 Valeo                         |                             |

### FEATURED BRANDS



### Smart Choice Terms & Conditions

Offers end 30th June 2019. All offers subject to availability and change without notice. Certain featured products may not be stocked by all members. Call your local IFA Member with any stock or pricing queries. These offers cannot be used in conjunction with any offer except at the discretion of your local IFA Member. All prices shown are exclusive of VAT. Pictures used are for illustrative purposes only and products are not shown at actual size or to scale. All product/marketing claims are the responsibility of the company on behalf of whom they are made and are not the liability of the IFA or its agents. E & OE.

All lease payment examples are based on a 60 month repayment period and with a NIL DEPOSIT facility. All lease figures quoted are subject to VAT and status. Alternative lease plans are available and can be tailored to your exact requirements. If you have any questions regarding lease facilities please call Alliance & General Leasing on 02478 220 000.

# SPECIALIST LIGHTING



RCV2210

**6 LED amber strobe**



**£26.24**  
+VAT

RCV2212

**3 LED amber strobe**



**£23.74**  
+VAT

RCV2213

**8 LED amber strobe**



**£27.49**  
+VAT

RCV2214

**4 LED slimline amber strobe**



**£12.49**  
+VAT

RCV2215

**6 LED slimline amber strobe**



**£13.74**  
+VAT

RCV2216

**6 LED slimline amber strobe**



**£24.99**  
+VAT

RCV9812 / RCV9813

**TruckMaster LED amber light bar**  
Magnetic mount / Single bolt mount



RCV9812  
Magnetic mount

RCV9813  
4 bolt mount

**£107.49**  
+VAT

**£107.49**  
+VAT

RCV9822 / RCV9823

**TruckMaster LED amber light bar**  
Magnetic mount / Single bolt mount



RCV9822  
Magnetic mount

RCV9823  
Single bolt mount

**£87.49**  
+VAT

**£62.49**  
+VAT



[www.ringautomotive.com](http://www.ringautomotive.com)



[/ringautomotive](https://www.youtube.com/ringautomotive)

# Lucas

## ZMB258 Single Box 24v Bulb Stand



**ONLY  
£115.00**

**ASK YOUR LOCAL  
BRANCH FOR DETAILS**

[www.lucaselectrical.co.uk](http://www.lucaselectrical.co.uk)

### SINGLE BOX BULB STAND WITH 200 OF THE FASTEST MOVING 24v BULBS

A GREAT VALUE INSTANT  
DISPLAY AND STOCK SOLUTION  
FOR GARAGES

#### Lucas Branded

The Lucas Brand is one of the most  
recognisable and trusted brands in the UK  
automotive aftermarket.

Ready to hang - stocked with 200 Bulbs

200 essential bulbs as follows:

BULB	QTY	BULB	QTY
LLB149	30	LLB346	10
LLB150	20	LLB507	10
LLB241	10	LLB508	30
LLB242	10	LLB508TAC	10
LLB246	10	LLB460	5
LLB248	10	LLB466	5
LLB249	20	LLB475	5
LLB294	10	LLB775	5

**Trust Lucas**



DRIVEN BY POSSIBILITY™



# COOLRUNNER™ BELTS

## - DRIVING PROFIT OPPORTUNITIES FOR WORKSHOPS

When any truck breaks down, it's unwanted downtime and an additional cost to the operator. When the fridge unit on a food distribution vehicle breaks down, the cargo could be lost as well.

CoolRunner™, from Gates, is the new name in replacement drive belts for on-board vehicle refrigeration units. It's also the latest example of how the drive systems manufacturer is able to supply Original Equipment (OE) quality products to provide solutions for independent repairers.

Gates is not new to the truck maintenance market. The Gates brand is an established OE supplier of accessory belt drive systems to many of the world's leading truck marques. For over 25 years, the drive systems manufacturer has been supplying drive belts for the on-board refrigeration units fitted as OE to vehicles and trailers used by the transport industry temperature controlled logistics specialists.

Specialist temperature controlled distribution operators must protect themselves against refrigeration unit drive belt failure – one reason

why the repair market is dominated by the OE networks. In some EU countries, these are independent agents that offer a 24-hour call-out service. Premium prices can be charged because operators are under pressure to get vehicles back on the move before cargoes perish and before delivery deadlines are missed.

This opens up profit opportunities for local independent repairers able to provide the right parts at more competitive prices and able to install them at aftermarket rates.

Many of the belt drive systems operate without tensioners, which makes the CoolRunner™ range easy to install. Other advantages include exact OE fit, a competitive price range and rapid OE cross-referencing.

Confidence in the Gates brand is high and the attractiveness of the CoolRunner™ range is such that workshops will appreciate the revenue potential from an ability to offer operators a local, low cost parts and installation alternative to the OE networks.



GATES NO.	CARRIER NO.	THERMO KING NO.
CB0001	506028810	780336 / 781340
CB0008		780679 / 2925B06H89
CB0012		781026 / 9170C56H16
CB0023	506028845	
CB0030	506028833	

## EU390 SERIES LOW-PROFILE MULTIFUNCTION TRAILER LAMP

STOP / TAIL / INDICATOR / FOG / REVERSE / TRIANGLE REFLECTOR



- 12/24V Multivolt
- 5 Year Warranty
- Fully ECE Approved

EU390L Left  
EU390R Right  
EU390LR2 Twin Pack



ledautolamps-uk.com

## HB SERIES HAMBURGER LAMPS

STOP / TAIL / INDICATOR • 12/24V • ECE



HBL140STIM 83mm depth  
HB140STIM 'Slimline' 40mm depth

## MARKER AND NUMBER PLATE LAMPS

• 12/24V Multivolt • ECE • IP67



129WM Fron Marker  
129RM Rear Marker  
129AM Side Marker

EU38WM Front Marker  
EU38RM Rear Marker  
EU38AM Side Marker

44WME Front Marker  
44RME Rear Marker  
44AME Side Marker

41BLME Number Plate Lamp

**EU390LR2 TWIN PACK ONLY £155.00**

Available from your local branch

## febi QUALITY DRYERS

With its Euro 5 engine, the TGX is one of the biggest trucks available from MAN, and offers a better fuel economy than other models. The 440 engine does not require AdBlue, offering even more incentive. The larger variants do require the addition of AdBlue, but some argue these models have an even greater fuel performance.

MAN have a great reputation for reliability and low maintenance costs, and with the fuel efficiency of the TGX, these trucks have proven very popular. febi Truck supply over 500 parts for the MAN TGX in range.

### Common problems

From the outside, differences in dryer design for air conditioning units in trucks, including the MAN TGX, are unnoticeable. However, the inner parts often deviate from the original design and frequently fail to fulfil the required function. Differences in the amount of desiccant employed are common.

If a substandard dryer is used, humidity in the refrigerant circuit may increase. This raised water content leads to corrosion in the system, causing wear of the air-conditioning unit's individual components. Plus, ice formation in the expansion valve disables the air-conditioning system altogether.

### febi has the solution

febi's OE matching quality dryers ensure the full function of components as required. We recommend a replacement interval of 2 years for the MAN TGX, to prevent humidity damage.

In addition to dryers, febi offers a vast range of other OE matching quality components for vehicle air-conditioning units to fit the MAN TGX, including air-conditioning compressors and expansion valves.

Part Number	Description	OE Number	To Fit
44473	Fan Coupling	51.06630.01 40	MAN TGX (2006-)
102633	Water Pump	51.06500.71 30	MAN TGX (2006-)
102298	Flywheel	51.02301.60 93	MAN TGX (2006-)
101835	Steering Column Switch Assembly	81.25509.01 57	MAN TGX (2006-)
49477	Pressure Switch	81.25503.02 44	MAN TGX (2006-)
48757	Vibration Damper	51.02201.01 51	MAN TGX (2006-)
48588	Air Temperature Sensor	51.27421.01 65	MAN TGX (2006-)
46448	Fuel Pump	51.12101.71 41	MAN TGX (2006-)
47018	Switch Unit	81.25806.71 07	MAN TGX (2006-)

Ferdinand Bilstein GmbH + Co. KG | Wilhelmstr. 47 | 58256 Ennepetal | Germany

febiTruck



# SOLUTIONS MADE IN GERMANY™



When it comes to quality and fitment, choose febi Truck. The entire range can be found at:  
**[partsfinder.bilsteingroup.com](http://partsfinder.bilsteingroup.com)**

The febi product brand is part of the bilstein group, which also incorporates the strong SWAG and Blue Print brands. Further information can be found at:  
**[www.bilsteingroup.com](http://www.bilsteingroup.com)**

**bilsteingroup®**



Donaldson®  
FILTRATION SOLUTIONS

# DAF

# BEST IN CLASS

MODEL	ENGINE	AIR	OIL / LUBE	FUEL	TRANS-MISSION	CABIN
CF85	XE series	P781525/ P784525	P550630	P550778 (FWS)	P762756	P785365
			P550661	P551856 (FWS)	P954605	
XF105	MX series	P784525	P550812	P550863	P954605	P785365
				P551856/ P550778 (FWS)		
XF106	MX series	P951919	P550952	P550863	P954605	P788881
		P786443	P550812	P551856/ P550778 (FWS)		
XF106	MX series	P951919	P550812	P559118	P954605	P788881
XF95	XE series	P781525	P550630	P550631		P788881
			P550663 (OC)	P551856 (FWS)		

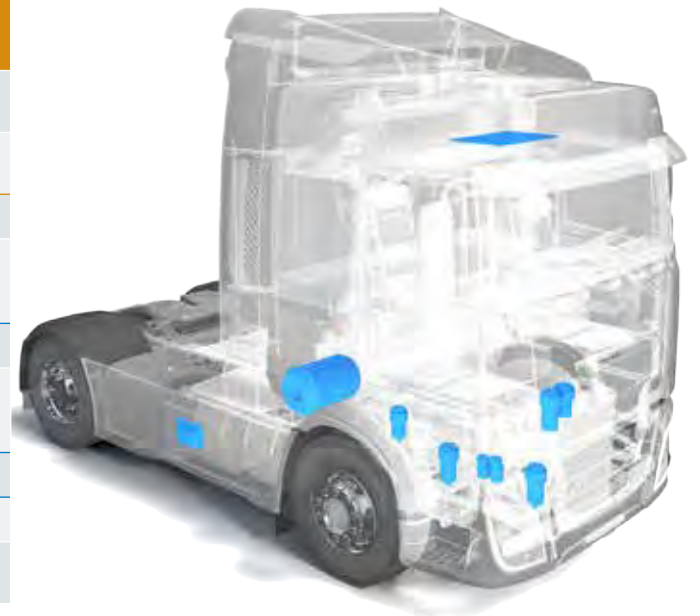

Donaldson filters are built for the road, to endure and perform.

Order from your local branch today!

**KEEP MOVING.**

**CARWOOD**  
Diesel Systems

## CV Diesel Injectors & Pumps

Approved diesel centre for all leading OE diesel system manufacturers, including:



[www.carwood.co.uk](http://www.carwood.co.uk)

### Delphi DMCI SMART Injectors & Unit Pumps for Euro 4/5 DAF CF & XF models



#### Why Carwood?

- ✓ Units remanufactured in state-of-the-art UK facility
- ✓ Genuine Bosch & Delphi replacement parts used
- ✓ Tested to genuine Bosch & Delphi OE specifications
- ✓ Tests carried out on Bosch & Delphi test machines
- ✓ Available in engine sets or single units

### Bosch Common Rail Electronic Injectors & Pumps for DAF CF & LF models



- ✓ 24 Month Warranty on Common Rail & DMCI products\*
- ✓ Test & Report service incl. free collection – Ask for details
- ✓ Scania, Volvo, Mercedes-Benz, Iveco, Renault, MAN also available
- ✓ Inlet connectors (tubes) available

**Call your local branch for more details and prices**

\*Warranty subject to T&Cs. OE boxes supplied where applicable

APV3228  
TO FIT DAF APPLICATIONS

# Dayco Heavy Duty. Your global partner from OE to the Aftermarket.

At the heart of the auxiliary drive system is the belt, which, depending on the application, will be of either V or Poly-V (multi-grooved) design.

Despite their relatively simple design, Dayco's V-belts, which consist of more than 150 part numbers, are manufactured from premium quality materials to provide strength and durability, while providing optimum resistance to oil, grease, heat, chemical agents, and ozone, as well as continuous flexing.

In contrast, the company's Poly-V belts, which consist of more than 360 part numbers, are made of EPDM and manufactured to the latest design criteria to deliver the very best in contemporary belt performance. With a larger contact area compared to a V-belt, the Poly-V belt is capable of driving a greater number of ancillary components and can also transfer power from its outer surface, which, depending on the application, can be either smooth, textured or ribbed.

Due to the fact that the load is spread across the belt, Poly-V belts are comparatively thin and therefore have tremendous flexibility, which means they are also able to be used on small diameter pulleys, increasing the scope for engineers when seeking the ideal solution for the drive systems of new engine designs.

To ensure the ancillary components on the system are driven in accordance with their design specification, the drive belt must be kept at the correct tension and under a controlled load. This is made possible by the use of tensioners and idlers and with the increasing power of modern engines, allied to the growing number of auxiliary components driven by the belt, these drive components are now highly developed and engineered to exacting standards. Dayco's HD tensioner and idler range now comprises more than 190 part numbers.

## AFTERMARKET ASSURANCE

When it comes to the aftermarket, independents can rest assured that all of Dayco's OE pedigree flows through to its aftermarket offering because the company's manufacturing facilities, engineering processes and finished products are identical for both its OE and aftermarket supply channels.

Both therefore reflect the latest technology, so technicians can be assured of the correct installation when it comes to the components, which means the fitting time is minimised, alignment of the auxiliary system optimised and the correct function of the components in the auxiliary drive system is secured.

In order for technicians to carry out the best possible job and fleet managers maximise the reliability of their vehicles, the auxiliary drive system should be considered as a single entity, instead of looking at the belt and drive components separately. Therefore, rather than changing individual items, technicians should replace the complete system, which allows them to provide a thorough repair solution.

## CHECK & CHANGE

Should an auxiliary belt fail, alongside the need to replace the affected parts, the vehicle's time off the road must also be factored into the potential cost of ignoring the condition of the belt and recent figures obtained from leading industry journal Commercial Fleet reveal that, dependent on its load, a typical HD vehicle working on a daily national delivery contract, could cost the owner up to £500 a day while it is out of action. In addition, there is also the cost of road side repair or recovery of the vehicle. However, applying Dayco's 'check & change' principal every time a vehicle enters the workshop, only takes a moment and will mitigate these financial costs.

## FOCUS ON DAF

Dayco part numbers APV2812, APV2813 and APV3228 – a single idler pulley, tensioner and tensioner with idler assembly respectively, fit the popular DAF CF and XF Series applications. The engine in these applications, which has been manufactured from 2005 onwards, utilises two drive belts in the auxiliary system, the first a seven-groove alternator belt, which incorporates the separate idler pulley and

tensioner and the second, a nine-groove belt that drives the water pump using the tensioner/idler assembly.

It is worth noting, that there are two alternative belts for each system, dependent on whether the vehicle is equipped with air conditioning or not, so the correct replacement belt must be identified before being fitted.



Leader in engineering and production of OE HD tensioners. OE HD belts designed for diesel grade HD applications. High performance and reliability. The preferred partner of the most important OE truck brands and engine equipment. VOLVO, CNH-IVECO, MERCEDES, MAN, SCANIA, CUMMINS, CATERPILLAR.

**DAYCO**®

MOVE FORWARD. ALWAYS.™

**To find out more call us in branch today!**

# SAVILLE

## THE LEADING DISTRIBUTOR OF WORKSHOP CONSUMABLES

Outstanding value for all your day-to-day requirements



### TR100 TOILET ROLLS

Pack of 36

- White
- 2 ply
- 200 sheets per roll

**£9.95 per pack**



### CFR100 CENTRE FEED ROLLS

Pack of 6

- 2 Ply
- Blue Embossed
- 104m x 175mm

**£9.95 per pack**



### SWC250 STEERING WHEEL COVERS

250 covers per box

- White
- 20 micron;
- Supplied in handy dispenser box

**£7.75 per box**



### SCR100 SEAT COVER ROLL

Box; 100 covers per roll

- White
- 12 micron
- Supplied in handy dispenser box

**£11.95 per box**

### DFM25 DISPOSABLE FLOOR MATTING

Pack of  
250 mats

- Strong brown paper

**£11.65 per pack**



### CL425 CHAMOIS LEATHER

4.25 - 4.5 sq ft

- Quality natural product
- Genuine sheepskin chamois leather tanned with 100% cod oil

**£9.99**



### JS101 JUMBO SPONGE

Pack of 6

- Synthetic sponge

**£4.50**



### GLF1 FURNITURE HIDE GLOVES

- Grain furniture hide
- Safety cuff
- Palm lining
- Elastic tensioner
- Rainbow - multi-coloured
- Striped cotton fabric
- Knuckle strap

**£1.45 per pair**



### GLP1 PVC DIP KNIT WRIST GLOVES

- Medium weight PVC dip
- Cotton interlock liner
- Smooth finish
- Abrasion resistant
- Knit wrist

**£1.45 per pair**

### ALSO AVAILABLE:

### COMFIT Disposable Gloves

- High quality at competitive prices
- Latex, vinyl and nitrile
- Powdered and powder-free

### THE COMFIT RANGE INCLUDES:

- Black Rhino Premium Heavy Duty
- Orange Microtex Fully Textured



CONTACT YOUR LOCAL BRANCH FOR THE COMPLETE SAVILLE CONSUMABLES RANGE



Commercial Vehicle Products



**TEXTAR**  
BRAKE TECHNOLOGY

Innovation. High Performance. Safety.  
Yesterday. Today. **Tomorrow.**

**Knorr-Bremse  
SB7 ProTecS®**

**2933101:  
Truck application**

Dimensions:  
247.3 (width) x  
109.5 (height) x  
30mm (thickness)  
Front & Rear Axle  
Scania 4 Series (05/95>)  
Scania P, G, R & T Series (01/03>)  
OE Refs: 2271804 & 2325212



**2933102:  
Bus application**

Dimensions:  
247.8 (width) x  
109.5 (height) x  
30mm (thickness)  
Front & Rear Axle  
Scania 4 Series (09/95-09/04)  
Scania 94 Series  
Irizar PB (07/02>)  
K Series (01/06>)  
OE Refs: 2271805 & 2325213



**2933606  
To fit:  
Schmitz Cargobull trailer**

OE Ref: 1195232  
Max™ 22T Brake System  
Dimensions:  
210.6 (width) x  
109.3 (height) x  
32mm (thickness)  
Trailer Axle



- ✓ No changes to geometry required
- ✓ Lower CO<sub>2</sub> emissions
- ✓ Clear advantage in Total Cost of Ownership for fleets
- ✓ Lighter than conventional backing plates



**WIN FREE TICKETS TO CONVOY IN THE PARK 2019 –  
SEE PAGE 13 FOR DETAILS**

## New-to-range from Haldex: The Grau 24/30 Brake Chamber

# HEAVYWEIGHT STOPPING POWER

**Grau**  
a Haldex brand



Part no.  
3462430001

### KEY BENEFITS

- Internal coil spring diameter is 0.5 mm larger than spring used in other manufacturer's designs, improving lifetime of spring by > 30%
- The power spring adopts a limit device to extend the service life of the parking cavity
- Surface treatment and anti-corrosion coating extend the service life of salt spray
- Double "O" ring sealed centre section protects against air leakage and prolongs service life
- Special crimping method eliminates the risk of accidental release of the power spring and enables low profile clamp-free interference
- Steel inner rod and slotted centre seal design improves the alignment of moving parts, prevents premature wear of seals and increases service life
- The travel indicator provides a visual inspection function for proper brake adjustment

### TECHNICAL SPECIFICATIONS

Version	24/30
Push rod (mm)	285
Push rod thread	M16 x 1.5
Protection	Wiper
Yoke	c/w
Side port	M16 x 1.5
Mounting thread	M16 x 1.5
Breather pipe	w/o
Side port (degrees)	90
Max. operating pressure (bar)	10
Stroke (mm)	76

Because it's from Haldex, every Grau brake chamber is tested to the most rigorous standards. All testing is carried out in accordance with SAE J1469.

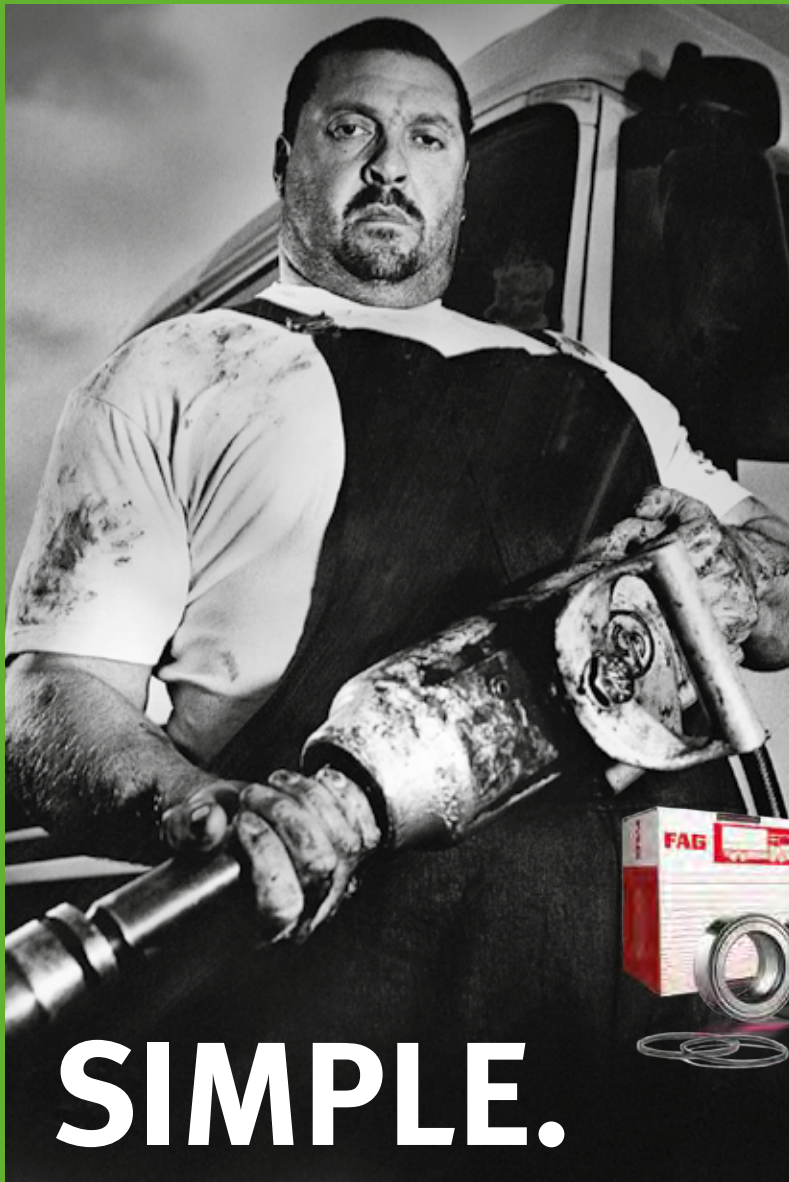

# FAG

## We haven't reinvented the wheel. Just how to repair it...

Why replace an entire wheel hub when it can be repaired quickly, simply and efficiently saving both time and money? The FAG Repair Insert Unit (RIU) from Schaeffler is a complete truck hub repair solution in a box:

- **Cost efficient** - reducing downtime and parts costs
- **Pre-assembled** - ready to fit
- **Pre-lubricated** - service free
- **Easy-to-install** - complete with fitting tool and instructions
- **Fits many DAF applications**  
*plus Renault, SAF, Schmitz-Cargobull, Volvo and more*



[www.repxpert.co.uk](http://www.repxpert.co.uk) | [www.schaeffler.co.uk/aftermarket](http://www.schaeffler.co.uk/aftermarket)



**SCHAEFFLER**

# SIMPLE.

# Indirect intercoolers for commercial vehicles



- Reduction of NO<sub>x</sub> values (nitrogen oxides)
- Reduction of CO<sub>2</sub> emissions and fuel consumption
- Helps commercial vehicles meet the latest Euro 6 standard



## What is intercooling?

Intercooling increases the air density in the cylinder and reduces combustion temperature. In the case of indirect intercooling, the charge air is not cooled by air – as is usually the case – but by a liquid coolant, a water-glycol mixture such as the one also used for engine cooling. The charge air waste heat is transferred to the coolant first, and is then discharged to the surrounding air in the low-temperature coolant radiator. The advantage of this system is that situation-dependent temperature control of the compressed air in the engine is possible through controlled intercooling. In turn, this contributes to an optimum engine operating temperature. In the case of diesel engines, it also increases the regeneration speed of the particulate filter.

Indirect intercooling components meet the requirements necessary for increasing engine performances coupled with reduced emissions: greater charge air pressure with higher air density and a lower intake temperature.

This means the intercooler design allows further so-called “down-sizing” with subsequent reduction of fuel consumption, and it is also sturdy and can cope with increasing charge air pressure in future. An intermediate indirect intercooler is required for modern commercial vehicle engines with two-step charging.

Due to improved cooling of the charge air, the NO<sub>x</sub> emissions caused during combustion can be significantly reduced. This helps commercial vehicles to meet the latest Euro 6 standard.

## How does it work?

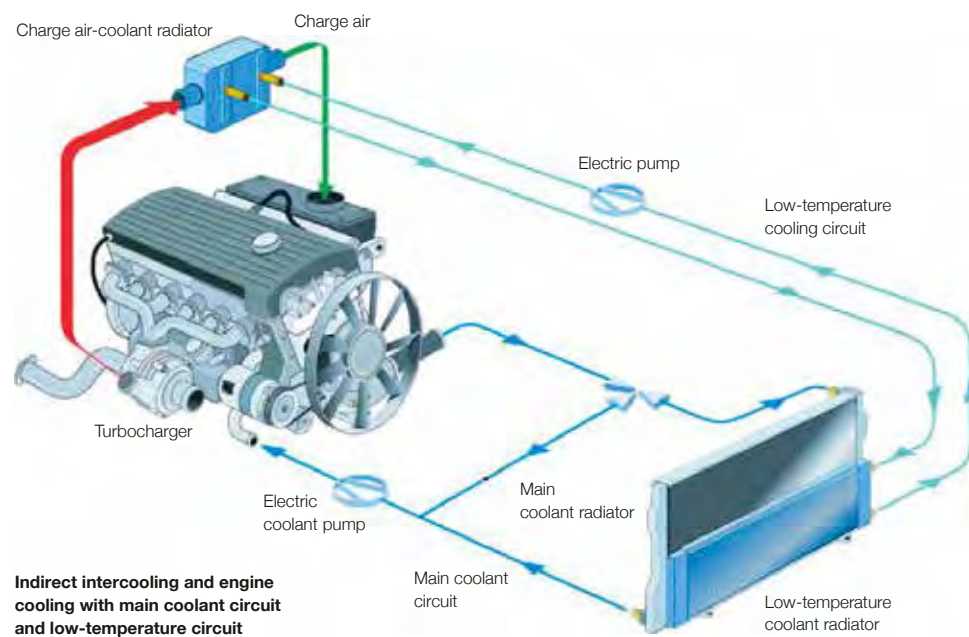

## Product overview

Part no.	Description	OE numbers*	Application
<b>8ML 376 756-001</b>	Indirect intercooler	<b>51095007129</b>	MAN TGL / TGM Series 6-cylinder engines
<b>8MK 376 755-411</b>	Low-temperature radiator for indirect intercooling	<b>81061010063</b>	MAN TGL / TGM Series

\* OE numbers are for comparative purposes only

# BPW BRAKE



# DRUM & BRAKE SHOES



There is **NO** difference between BPW original equipment and its aftermarket components.

## FEATURES

- ⦿ Made in BPW's own factory using specially developed steel alloys for guaranteed quality.
- ⦿ Anchor seats and two-piece rollers induction hardened and broached.

## BENEFITS

- ⦿ Brake shoes dip-coated with zinc-phosphating (KTL-zn) for enhanced surface protection.
- ⦿ Brake shoes profiled to match BPW drum for optimum performance.

## Performance. Reliability. Security.

BPW sets the benchmark worldwide for no-compromise top quality products which meet the highest demands for quality and reliability. BPW original parts are continuously being developed and offer you the security of knowing they are built to match your running gear.



Get an Axle Set of brand-new, genuine BPW shoes, relined with BPW linings, spring fitting kit and drums for **ONLY £350.00!**

Contact your local branch today!

# PRESTOLITE ROTATING ELECTRICS

## THE ONLY UK MANUFACTURER OF STARTERS & ALTERNATORS

**ORIGINAL EQUIPMENT QUALITY STARTER MOTORS & ALTERNATORS FROM AN OE MANUFACTURER TO THE EUROPEAN TRUCK INDUSTRY.**

Prestolite is an Original Equipment supplier to over 40 European vehicle and engine manufacturers. These businesses choose Prestolite, Scania, MAN, Van Hool, Iveco, Alexander-Dennis, Wright Group, Optare, Cummins, CAT, MTU etc.

Prestolite Electric Starter Motors & Alternators for trucks are brand new, with no surcharge or old core requirement.

Prestolite are at the forefront of design & technology for heavy duty OE manufacturers and that know how is used in our range of aftermarket rotating electrics.

Fitting a new Prestolite Starter or Alternator will ensure that it functions correctly for the intended application, giving you peace of mind, unlike some other imported 'copies' currently on the market!.



**FOCUS ON  
DAF**

### DAF LF45 / 55 Alternator



Prestolite ref: 860815  
OE ref: 1387381, 1387381R,  
1387383, 1387383R,  
1703434, 1704911, 1704911R,  
AELD021, AELF189, AELF405

### Starters



Prestolite ref:  
860806GB (110amp)  
OE ref: 1540481



Prestolite ref: M93R3105SE  
(Upgrade for 860815  
– gives 25% more power!)



**SMART  
PHONE**

**CALL FOR  
OUR BEST  
PRICES!**

### DAF XF106 Starter

Prestolite ref: M90R3564SE  
OE ref: 1886891, 1956091,  
1956091R, 2015154, 2015154R



**NEW TO  
RANGE**

**AVAILABLE  
APRIL 2019!**



**SMART  
PHONE**

**CALL FOR  
OUR BEST  
PRICES!**



Contact your local IFA member for more details about our full range of aftermarket rotating electrics.

**Prestolite**  
electric

## CONVOY IN THE PARK

10/11 AUGUST 2019 - DONINGTON PARK

## COMPETITION TIME!

**TEXTAR**  
BRAKE TECHNOLOGY

Thanks to Textar Brake Technology we're giving away a pair of weekend tickets to Convoy in the Park 2019 absolutely FREE!

One lucky customer will WIN a fabulous prize of a pair of tickets. Simply buy any 2 sets of brake pads from this issue of CV Smart Choice (see page 9 for details) and you will be automatically entered into the prize draw.

Closing date for entries is 30th June and the winner will be announced in July. Terms and conditions apply. Visit:

[www.smartchoicemagazine.co.uk/competition/terms](http://www.smartchoicemagazine.co.uk/competition/terms) for more details.

**GOOD LUCK!**





SIDE VALANCE • QUARTER FENDERS  
OE TRACTOR UNIT MUDFLAPS

Netroute Side Valance



- Single Construction Side Valance
- Extruded from HDPE, high impact strength
- Widely fitted by many major European Fridge Trailer Builders
- For speed & easy fitting there are 3 types of aluminium rail available
- Complies with European Directive (EU)109/2011
- One piece valance supplied in 4 metre lengths
- Homologation No. Ae2 00 15163 Side Valances & Quarter Fenders

Full Trailer Kit  
Price from  
**£260**

Part No.	Width	Length	Depth	Description
F-4640	460mm	400mm		Quarter Fender
F-4660	460mm	600mm		Quarter Fender
F-150102	-	4000mm	100mm	Side Valance
F-160049	-	4000mm	150mm	Side Valance
F-961248	-	4000mm	-	Mounting rail – for Side Surface Mounting
F-961249	-	4000mm	-	Mounting rail – for fitment under vehicle body
F-020647	-	4000mm	50mm	Mounting rail – extended rail for fixing to underside of vehicle body. Increases overall valance depth to 200mm when used with Valance part no F-020154
FNW-055056	440mm	1000mm		Trailer Flap to suit F-4660

Shaped Netway® Tractor Unit Mudflaps

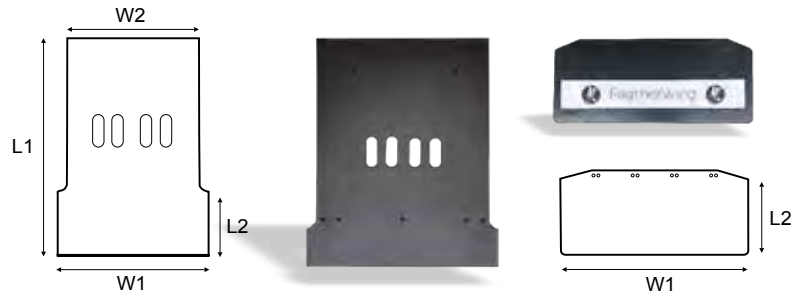

- Widely fitted as OE by European Truck Manufacturers, including DAF, Renault, Volvo, Scania etc
- Lightweight polyethylene construction. 100% recyclable
- Complies with European Directive (EU)109/2011
- Netway can be cut and shaped without losing product integrity
- Homologation No. A e2 12091

Prices from  
**£30**

Part No.	Width (W1)	Width (W2)	Length (L1)	Length (L2)	Application
FNW-055069	690mm	620mm	1100mm	400mm	Universal
FNW-092181/D1	690mm	660mm	740mm	280mm	DAF
FNW-092181/D2	690mm	660mm	790mm	330mm	DAF
FNW-092181/V	690mm	670mm	830mm	280mm	Volvo
FNW-092181/RT	690mm	670mm	830mm	280mm	Renault
CPF2812-SC1	710mm			305mm	Scania

The leading name in commercial vehicle mudguards, spray suppression equipment, bracket systems and ancillary products. For more information please contact your local branch today!

Trusted by these leading manufacturers:

**DAF • CUMMINS • MAN • RENAULT • PERKINS • MERCEDES • SCANIA • VOLVO • IVECO**

**GET A FREE REGATTA JACKET  
COURTESY OF BTN TURBO  
DURING MAY!**

- All turbos supplied are 100% OE
- 2 year warranty on all turbos
- 1 year No Quibble on Heavy Commercial Vehicles
- Over 2,500 part numbers



Promotion runs 01/05/2019 - 31/05/2019

Technical helpline available for diagnostic information on 01895 466663 or www.bnturbo.com

Please note: All offers end 30 June 2019 and are subject to availability. All prices exclude VAT.

See the back page for branch contact details.

FGas  
Training  
£129\*

# FULLY AUTOMATIC A/C MACHINES

Designed to deliver the best refill service



**Demonstration available on request**

\*£129 for first candidate when a machine is ordered

## Valeo Window Regulators for Commercial Vehicles

- **Product Range covers references for the top 7 UK truck manufacturers including, DAF, Scania & Volvo**
- **485,000 vehicles are covered with the Valeo range in the UK truck parc**



**Valeo**

# Specialist tools from Knorr-Bremse Truck Services

COMBINING ROBUSTNESS WITH LONG LIFE AND PRECISION

## EAC BAYONET CARTRIDGE TOOL

**K162153K50**

The special tooling for bayonet rings from Knorr-Bremse assists in the release and tightening of the bayonet ring on bayonet cartridges. As a result, service actions on the bayonet cartridges of EAC2.5 (Electronic Air Control) for Volvo/Renault applications, can be performed easier, quicker and in a safer way.



## BRAKE DISC MEASURING GAUGE

**K146719K50**

As an additional service Knorr-Bremse introduced its Brake Disc Measuring Gauge. By following a few simple steps, the gauge enables a quick and clear assessment of the wear condition of all 17.5", 19.5" and 22.5" brake discs without removing the wheel. This simple tool will show you if your brake disc needs changing in just a few seconds!



## TRAILER EBS TOOL KIT

**K148897K50**

The Extraction Tool Case for Trailer Modules was developed by Knorr-Bremse R&D department and finalized in cooperation with one of the leading companies producing special tools: Gedore Automotive. Quite often it can be difficult to access electrical connections on the TEBS modules, but these special tools from Knorr-Bremse allow you to easily:

- Release the electrical connectors from the Trailer Module
- Release and tighten the power supply connector (bayonet nut)



## TOOL CASE FOR CLUTCH COMPRESSORS

**K052066K50**

The Clutch Compressor tool case was developed in cooperation with one of the leading companies producing special tools: Gedore Automotive. The special tools from Knorr-Bremse will support mechanics in the following service actions:

- Dismounting the clutch
- Replacing the actuation piston
- Mounting the clutch
- Mounting the output shaft



## AIR DISC BRAKE TOOL KIT

**K039062K50**

This kit contains all tools required to service all types of Knorr-Bremse calipers. Without the use of professional equipment, crucial parts like guide pins, seals and tappets can be damaged or a substantial amount of extra time will be needed by the workshop.



ASK YOUR LOCAL BRANCH ABOUT THE FULL RANGE OF SPECIALIST TOOLS AVAILABLE FROM KNORR-BREMSE TRUCK SERVICES



# TRAFFIC FILM REMOVER

**Using QRP25L in a pressure washer which can only dilute to 2%?**

Simply pre-dilute for the required strength:

- 1 equal volume of water (1% strength)
- 2 equal volumes of water (0.5% strength)

**25 Litre Multipurpose Traffic Film Removers**  
Degrease engines, chassis & components

**Special offer on bulk quantities**  
Call your local IFA Member to order



### QRP25L

- Use at 0.5 to 1% (see above)
- High alkalinity - superior clean & grease cutting
- Dewaxes (polymer wax)
- Cost effective!

### QYP25L

- Use at 1% dilution
- Cost effective!

### QPP25L

- Use at 1%
- Contains wax for a superior finish
- Cost effective!

### QGP25L

- Use at 2%
- Ideal for sign written cabs
- Economical



\* At the dilution rate shown for the product.



# MAHLE

» Quality is synonymous with holding to a standard. The original equipment standard, for instance.

» The quality of a supplier is also measured by the quality of the information that he makes available to his partners.

» In the right place at the right time. Or how do you define availability?



## FUTURE SOLUTIONS. FOR YOUR SUCCESS.

» Width x depth — this is the formula for a demand-driven product range.



» The independent repair shop is exactly what its name suggests: it is independent — and wants to stay that way.

» For the future, you require a partner who knows what you will need tomorrow and the day after — because it is already in his range today.

[WWW.MAHLE-AFTERMARKET.COM](http://WWW.MAHLE-AFTERMARKET.COM)





# DRAPER HAS THE RIGHT TOOL FOR EVERY JOB!



26695

## HI-TORQ® METRIC COMBINATION SPANNER SET

6 Piece

- Generally in accordance with DIN3113 specifications.
- Forged from chrome vanadium steel hardened, tempered and chrome plated for corrosion protection.
- Polished Draper HI-TORQ® ring end offset at 15°.
- Jaw offset at 15°.
- Supplied in wall mountable plastic storage rack.
- Display packed.
- Contents: 34, 36, 38, 41, 46 and 50mm.

**£93.95\***

83378

## CORDLESS GREASE GUN

18 Volt

- Expert Quality, designed to work with a standard 400g grease cartridge – either bulk or manual filled.
- Manufactured with a chromed steel canister, rubber reinforced delivery tube and a high pressure grease nipple.
- Supplied with two 18V Ni-MH battery packs and a one-hour quick charger.
- 8,000 PSI output delivers a constant 70g per minute flow rate.
- Includes a shoulder strap for ease of carrying.
- Display packed.

**£174.95\***

01815

## PNEUMATIC RISE RATCHETING AXLE STANDS

10 Tonne; Pair

- Expert Quality, pair of pneumatic axle stands fitted with an internal gas strut enabling an auto rising feature.
- Easily operated by activating a lever, which enacts the internal air driven post to rise until the saddle makes contact or the saddle reaches its maximum height.
- Once the correct height is achieved a locking pin keeps the saddle secured and the extra wide base of the axle stand provides added stability.
- Min./Max. height: 505mm/770mm.
- Capacity (max. per stand): 10,000kg (S.W.L.).
- Capacity (per pair): 20000kg (S.W.L.).

**£164.75\***

03494

## LONG CHASSIS TROLLEY JACK

10 Tonne

- Manufactured to EN1494 specification.
- Heavy-duty chassis fitted with a 'quick-lift' foot pedal to rapidly raise the saddle to the vehicle jacking point.
- Large saddle aids positioning.
- Locking facility allows the handle to be locked in three positions.
- T-shaped handle incorporates release valve to prevent accidental lowering.
- Rear swivelling castors with toe plate increases manoeuvrability.
- Safety valve prevents jack from overloading.
- Supplied with a one piece handle.
- Min./Max. height: 170mm/ 570mm.
- Saddle diameter: 130mm.

**£680.50\***

**Contact your local branch for details of our full range and our best prices!**

\* Please note: All prices EXCLUDE VAT

## WABCO MAXX™22 caliper full repair concept for DAIMLER Trucks

The Heavy Duty Air Disc Brake MAXX™22 has been supplied in series production to DAIMLER AG since October 2015 and is installed in certain models of the ACTROS, ANTOS and AROCS series.

### DAIMLER caliper OE number

- A0054201383 Caliper front left
- A0054201483 Caliper front right
- A0054201583 Caliper rear left
- A0054201683 Caliper rear right



### WABCO service parts

#### ■ Brake Pad kit

Part number: 640 322 958 2  
Content: 2, 3, 4, 5, 17

#### ■ Return unit

Part number: 640 322 941 2  
Content: 17, 18, 19, 20

#### ■ Boot

Part number: 640 322 942 2  
Content: 8, 17

#### ■ CWS

Part number: 640 322 943 2  
Content: 15, 16

#### ■ Bolts & Seals

Part number: 640 322 951 2  
Content: 9, 10, 11, 12, 13, 14, 17

#### ■ Pressure Plate (Left)

Part number: 640 322 945 2  
Content: 6

#### ■ Pressure Plate (Right)

Part number: 640 322 946 2  
Content: 7

**For order details please contact your local branch.**



# ATF PACKAGES

>> *Tecalemit Commercial Vehicle Equipment Range is the most comprehensive in the market*



OUR PRODUCTS AND SERVICE ARE INDUSTRY LEADING AND IF YOU ARE CONSIDERING PURCHASING AN ATF LANE YOU SHOULD DEFINITELY BE TALKING TO US. WE WILL BE PLEASED TO HELP.



Tecalemit ATF Lane

All equipment is installed & supported after sale by Tecalemit engineers.

## THE COMPLETE ATF PACKAGE

If you are a Commercial Vehicle servicing facility or an Operator and you are considering becoming an ATF, then talk to us first. We can offer the very best ATF testing equipment, supplied and maintained by Tecalemit. The DVSA approved equipment offers exceptional performance, unique features as standard and outstanding after sales support

Our ATF packages are tailored to suit each site and Operators requirements and can include:

- ▶ Pre-Fabricated Inspection Pits
- ▶ Hydraulic Pit Jacks
- ▶ Brake Testers
- ▶ Emission Testers
- ▶ Wheel Play Detectors
- ▶ Headlamp Beam Testers
- ▶ All ancillary products



Tecalemit has a team of highly experienced Service Engineers throughout the UK provide servicing, calibration and general equipment maintenance for our customers, ensuring your equipment remains in the best condition and provides outstanding service.

As part of the service we offer, clients will receive a free consultation and workshop planning guidance. CAD drawings can be prepared for submission to DVSA.

**No other manufacturer offers the products and after sales support of Tecalemit – call today for a consultation**



Tecalemit CV Workshop equipment is found in daily use in workshops throughout the UK.

Should you choose Tecalemit as your supplier, our range of services extends to provision of civil work and electrical contractors if required or, if you would rather use your own contractors we can work with them to ensure the site-preparation is completed to the standard required.

For the workshop Tecalemit offers a range of vehicle lifting solutions including mobile columns, scissor and platform lifts and a complete range of wheel servicing and OE approved ADAS equipment.

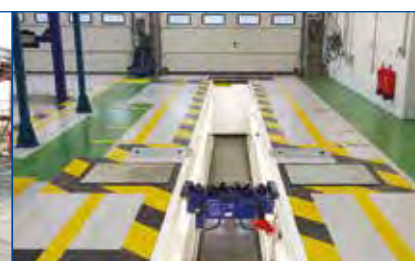

# NEW WINNARD BRAKE DISCS, HUBS AND HUB KITS

## WINNARD

### HUBKIT0001 DAF

**Vehicle applications:** DAF CF, LF & XF (2000>);  
Foden Alpha (2001>);  
Van Hool T9 (2003>) – Rear Axle  
**Hub OEM:** 1657637, 1812161



### HUBKIT0002 DAF

**Vehicle applications:** DAF CF, LF & XF  
(2000>); Foden Alpha (2001>);  
Van Hool T9 (2003>) – Rear Axle  
**Hub OEM:** 1389061,  
1391617, 1818003,  
1956105,  
2015333,  
2019853



### HUBKIT0004 DAF

**Vehicle applications:** DAF CF, LF & XF  
(2000>); Foden Alpha (2001>);  
Van Hool T9 (2003>) –  
Front Axle  
**Hub OEM:**  
1691621,  
1699327,  
1818004



### HUBKIT0007 RENAULT / VOLVO

**Vehicle applications:** Renault; Volvo B9R /  
B13R; Volvo FH / FM – Rear Axle  
**Hub OEM:** 20535263,  
7420535263,  
7485107753,  
85107753



### HUBKIT0003 DAF

**Vehicle applications:** DAF CF, LF & XF (2000>);  
Foden Alpha (2001>);  
Van Hool T9 (2003>) – Front Axle  
**Hub OEM:** 388905, 1391615 – check hub design,  
1697346 – check hub  
design



### HUBKIT0008 RENAULT / VOLVO

**Vehicle applications:** Volvo B7R / B9L / B9TL /  
B12B, B12M; Volvo FH – Front Axle  
**Hub OEM:** 1026798, 1026659, 20535202,  
21116569, 3989341, 3988930,  
85107750, 85111448,  
85111791, 85114470.  
7420535202,  
7485114470,  
7421024206 – see  
website for wheel stud  
options.



All Hub Kits are supplied with FAG bearing and ABS ring, plus brake disc and wheel studs fitted.

**GET A FREE  
SCHAEFFLER BODY  
WARMER OR PAIR OF  
OVERALLS WHEN YOU  
ORDER A WINNARD  
HUB KIT!**

**BUT HURRY - ONLY  
AVAILABLE FOR A LIMITED  
TIME ONLY, WHILE  
STOCKS LAST!**



**FAG**

ALL WINNARD HUBS ARE FITTED  
WITH FAG BEARINGS AS STANDARD

**CALL YOUR LOCAL BRANCH FOR OUR BEST OFFER PRICES ON THE FULL RANGE!**

CV SMARTCHOICE FROM

# PICKSONS

TRUCK & TRAILER PARTS

**AVONMOUTH**

**01179 821321**

**BRIDGWATER**

**01278 450152**

**BRISTOL**

**01179 721188**

**GLOUCESTER**

**01452 757500**

**SWINDON**

**01793 822922**

**YATE**

**01454 311848**

Offers available from 1 April – 30 June 2019 and are subject to availability. All prices exclude VAT and are correct at time of going to press. All images are for illustrative purposes only. We reserve the right to withdraw offers without prior notice. E&OE.